

Nexus®Pro Gateway



Features

- IoT Gateway designed to deliver Bluetooth® Mesh connectivity
- Gateway can be connected wired or wirelessly to WiFi Routers
- One gateway required per building structure within Nexus®Pro¹
- Each gateway communicates with up to 200 devices

¹Note that multiple gateways can be physically installed in a building, supporting up to 200 emergency units each; however, in the Nexus®Pro app, gateways must be configured within separate digital building structures (e.g. if two gateways were installed in "Main Building", the gateways could be configured in the Nexus®Pro app as "Main Building 1" and "Main Building 2").

Mounting

- Gateway supplied with a Din-rail that can also be used for wall installation

Electronics

- Supplied with a 24VDC output
- Supports WiFi connections on both 2.4 GHz and 5 GHz frequency bands for added flexibility

Approvals

- Suitable for installation indoors in a secure location 32°F to 104°F (0°C to 40°C)
- RoHS compliant

Warranty

- Unit has a five year limited warranty
Detailed warranty terms located online at:
www.emergi-lite.com/usa/files/EL_Warranty.pdf

Dimensions

Dimensions are approximate and subject to change.

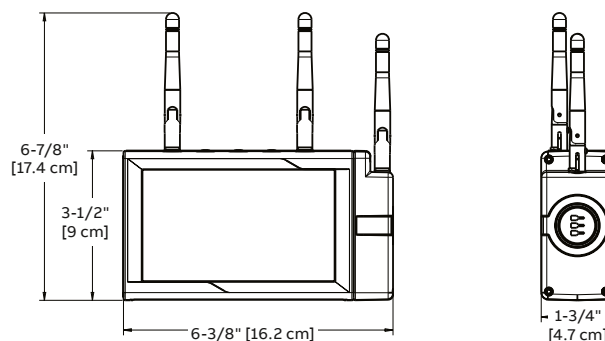

Weight

Catalog number	Weight
NEXP-GATEWAY-EL	1 lb

Power consumption

Catalog number	Power consumption
NEXP-GATEWAY-EL	4W typical, 15W maximum

Ordering information

Catalog number	Description
NEXP-GATEWAY-EL	Nexus®Pro IoT Gateway