

EMIU 720W Mini Inverter
 INTERRUPTIBLE EMERGENCY LIGHTING
 UNIT INVERTER INSTRUCTION MANUAL

IMPORTANT SAFEGUARDS

When using electrical equipment, basic safety precautions should always be followed, including the following:

READ THIS MANUAL AND FOLLOW ALL SAFETY INSTRUCTIONS THOROUGHLY BEFORE OPERATING THE EMIU INVERTER SYSTEM

i BEFORE CONTACTING TECHNICAL SUPPORT MAKE SURE TO FOLLOW ALL STEPS IN SEQUENCE AND REFER TO THE TROUBLESHOOTING GUIDE INCLUDED IN THIS MANUAL.

SAVE THESE INSTRUCTIONS

1. DO NOT USE OUTDOORS.
2. All unused wires must be insulated to prevent shorting.
3. Do not mount near gas or electric heaters.
4. Do not let power supply cords touch hot surfaces.
5. Do not use this equipment for other than its intended use.
6. The **EMIU** should be mounted securely and in locations and at heights where it will not be readily subjected to tampering by unauthorized personnel.
7. The use of accessory equipment and replacement parts not recommended by manufacturer may cause an unsafe condition and void the warranty.
8. The AC voltage rating of this equipment is specified on the product label. Do not connect the **EMIU** equipment to any other voltage.
9. Replacement fuse is supplied.
10. The **EMIU** uses sealed valve regulated lead acid batteries. Batteries can be punctured if not handled properly, therefore use caution when servicing batteries. In the event battery acid comes in contact with eyes or skin, flush with fresh water and consult a physician immediately.
11. Install in accordance with the National Electrical Code and local regulations.
12. The **EMIU** contains potentially hazardous voltages. Installation, maintenance and service work should be performed by qualified and trained personnel.
13. Electricians and end-users need to ensure product system compatibility before final installation.
14. Units to be installed only as per configuration described in this instruction manual.

MODEL NUMBER	AC SPECS		EMERGENCY POWER AVAILABLE FOR LOAD				APPROX. WEIGHT
			90 MIN	2H	3H	4H	
EMIU-720	120/277 VAC, 60Hz	9.6 / 4.0 Amps	720W	614W	437W	340W	230 LBS.

IMPORTANT: Do not exceed the total rating of the Mini Inverter. Unit is rated at maximum Watt and maximum VA, where Max.W = Max.VA. Total load (W) must be derated when load power factor (PF) is less than 0.9 (for maximum performance).

WARRANTY

All Emergi-Lite® inverter products receive 100% quality inspection before shipment to ensure proper and satisfactory operation. When operated under normal conditions, Emergi-Lite® inverter products will provide years of dependable service. This unit is backed by a 3-7 year warranty. The unit is covered by a complete 3-year warranty against defects in material or workmanship, and a 7-year pro-rata battery warranty.

**WARNING:**

THE MINI INVERTER MUST BE MOUNTED SECURELY USING A 1/4" (MIN) SCREW AND FLAT WASHER FOR EVERY KEYHOLE. THE MOUNTING SURFACE MUST ALSO BE SUFFICIENTLY REINFORCED TO ACCOMODATE THE WEIGHT LISTED (SEE PAGE 1). FAILURE TO SECURE THE UNIT SUFFICIENTLY CAN DAMAGE THE EQUIPMENT AND/OR CAUSE SERIOUS INJURY.



WARNING: DO NOT ENERGIZE THE CIRCUIT UNTIL ALL STEPS HAVE BEEN SUCCESSFULLY COMPLETED.

**WARNING:**

DO NOT CONNECT THE BATTERY(IES) UNTIL YOU ARE PREPARED TO START-UP THE UNIT PERMANENTLY. CONNECTING THE BATTERIES WITH THE UNIT OFF MAY DRAIN THE BATTERIES TO THE POINT THAT YOU WILL NOT BE ABLE TO START-UP THE UNIT.

**WARNING:**

FAILURE TO CONNECT THE BATTERIES PROPERLY MAY RESULT IN EQUIPMENT FAILURE OR AN UNSAFE CONDITION AND WILL VOID THE WARRANTY. A SMALL SPARK MAY OCCUR WHEN CONNECTING TO THE BATTERY WIRES. THIS IS NORMAL AND IS CAUSED BY LARGE CAPACITORS CONTAINED IN THE MINI INVERTER BEING CHARGED.

**WARNING:**

ALWAYS TURN OFF THE INVERTER MODULE AND THE AC SUPPLY TO THE EQUIPMENT AND DISCONNECT THE BATTERY BEFORE SERVICING. ONLY QUALIFIED SERVICE TECHNICIANS SHOULD SERVICE THIS EQUIPMENT. THE USE OF PARTS SUPPLIED BY OTHER THAN THE MANUFACTURER MAY RESULT IN AN UNSAFE CONDITION OR EQUIPMENT FAILURE AND WILL VOID THE WARRANTY.

**CAUTION:**

THIS UNIT PROVIDES MORE THAN ONE POWER SUPPLY OUTPUT SOURCE. TO REDUCE THE RISK OF ELECTRICAL SHOCK WHEN SERVICING, DISCONNECT BOTH NORMAL AND EMERGENCY SOURCES BY TURNING OFF THE A.C. BRANCH CIRCUIT AND BY DISCONNECTING THE BATTERY.

**CAUTION:**

BEFORE INSTALLING, MAKE CERTAIN THE A.C. POWER IS OFF.
NOTE: THE BATTERIES ARE SHIPPED SEPARATELY. PLACE THEM IN A LOCATION AWAY FROM THE WORK AREA TO AVOID DAMAGE UNTIL THEY ARE TO BE INSTALLED.

**CAUTION:**

ONLY ONE VOLTAGE IS ALLOWED (120V OR 277V). CONNECTION TO MORE THAN ONE VOLTAGE MAY RESULT IN EQUIPMENT FAILURE AND VOID THE WARRANTY.

**CAUTION:**

FOR NORMALLY ON UN-SWITCHED UNITS: THE JUMPER WIRE IS PRESET FOR 120VAC. IF THE UNIT IS TO BE WIRED FOR 277VAC, REMOVE THE JUMPER WIRE FROM THE 120VAC INPUT POWER TERMINALS AND REINSTALL THE JUMPER WIRE INTO THE 277VAC INPUT POWER TERMINALS.

**CAUTION:**

IF CONNECTED TO 277V INPUT, USE A 277V RATED SWITCH. FAILURE TO USE THE PROPER VOLTAGE SWITCH MAY RESULT IN SWITCH FAILURE, A SHOCK HAZARD, AN UNSAFE CONDITION AND/OR EQUIPMENT FAILURE.

**CAUTION:**

THE MINI INVERTER HAS A SELF-TEST FEATURE AND CAN ENTER IN SELF-TEST MODE (MONTHLY, BIENNIAL OR ANNUAL) AT ANY TIME. WHEN THIS OCCURS, POWER WILL BE AVAILABLE AT THE OUTPUT OF THE MINI INVERTER, EVEN IF THE LATTER WAS CONFIGURED FOR NORMALLY-OFF OPERATION. ALWAYS TURN OFF THE INVERTER MODULE INSIDE THE MINI INVERTER BEFORE WORKING WITH THE WIRING SYSTEM OF THE EMERGENCY LIGHTING SYSTEM.

**IMPORTANT:**

WHEN MAKING CONNECTIONS TO THE MINI INVERTER, YOU MUST RESPECT THE APPROPRIATE WIRING DIAGRAMS. DO NOT CONNECT THE "INPUT POWER" NEUTRAL TO THE "LOAD" NEUTRAL. FAILURE TO COMPLY WITH THIS DIRECTIVE MAY RESULT IN EQUIPMENT FAILURE AND VOID THE WARRANTY.

**IMPORTANT:**

FOR NORMALLY OFF LOAD: REMOVE THE JUMPER WIRE BEFORE WIRING THE UNIT.

INSTALLATION

STEP 1: MOUNTING THE MINI INVERTER TO THE WALL

- Remove the front cover of the Mini Inverter by removing the two screws at the top of the cover.
- Extend the unswitched, properly-rated voltage AC supply and remote fixture wires to the installation area.
- Use keyhole slots at the rear of the unit and mount the Mini Inverter securely to the wall.
- Connect the conduit containing the AC supply and remote fixture leads to the Mini Inverter. Use the provided knock-outs on the side of the Mini Inverter for connecting the incoming wires.
- Install the batteries at this time, but do not connect the battery leads until other wiring is completed.

STEP 2: CONNECT THE NORMAL AC INPUT (SEE FIGURE 2B)

- For 120V supply, connect the AC Line wire to the 120V (UN-SWT) position of the INPUT POWER section of the terminal block. For 277V supply, connect the AC Line wire to the 277V (UN-SWT) position of the INPUT POWER section of the terminal block.
- Connect the NEUTRAL wire to the NEUTRAL position of the INPUT POWER section of the terminal block.
- Connect the ground wire in accordance with local and national codes.
- For Nexus wired (option): Refer to the "WIRING FOR NEXUS®" on the page 4.

STEP 3: CONNECT THE REMOTE EMERGENCY FIXTURES (SEE FIGURE 2A, 2B, 2C OR 2D)

- Connect the remote emergency fixtures to the correct position of the LOAD terminal block, respecting the operating voltage. All remote circuitry is to be wired in accordance with Article 700 of the National Electric Code. **Do not exceed the total rating of the Mini Inverter. Unit is rated at maximum Watt and maximum VA, where Max.W = Max.VA. Total load (W) must be derated when load power factor (PF) is less than 0.9 (for maximum rating).** Special attention shall be taken when load consists of LED lamps with no built-in power factor correction. Example: most of the single LED lamps (Screw-on, GU-10, etc.) have a power factor of less than 0.6. This translates to a derating close to 50%.
- NORMALLY-OFF LOAD (only come on during power failure)** - Remove the jumper wire. Connect the AC Line input wire of the fixtures to the appropriate position of the LOAD terminal block (120V OR 277V). Connect the fixture Neutral to the Neutral position of the LOAD terminal block. Refer to Figure 2B.
- UN SWITCHED NORMALLY-ON LOAD** - Connect the AC Line input wire of the fixtures to the appropriate position of the LOAD terminal block (120V OR 277V). Connect the fixture Neutral to the Neutral position of the LOAD terminal block. Refer to Figure 2C.
- SWITCHED NORMALLY-ON LOAD** - (fixtures may be turned on and off locally, but will come on during power failure regardless of switched position) - Follow Step 3B above. Connect the Line side of the switch to the (UN-SWT) position of the INPUT POWER terminal block, respecting the operating voltage (120V OR 277V). Connect the load side of the switch to the (SWT) position on the INPUT POWER terminal block, respecting the operating voltage (120V OR 277V). Refer to Figure 2A.
- Connect the Fixture Supply Ground to the Mini Inverter Ground.

STEP 4: CONNECT THE BATTERIES

- Position the batteries in the unit.
- Refer to figure 1. Connect the Black jumper **ALONG WITH THE SMALL YELLOW WIRE** to the negative (-) post of one of the batteries. Connect the other end of the black jumper to the positive (+) post of the other battery. Connect the RED wire to the available positive (+) post of the first battery. Connect the BLUE wire to the available negative (-) post of the second battery. This assembly results in batteries that are in series. Tighten all bolts to a recommended torque of **78 lbf-in ± 4 lbf-in**.

STEP 5: SWITCH ON THE INVERTER MODULE (SWITCH IS LOCATED ON THE RIGHT SIDE OF THE INVERTER MODULE).

NOTE: THE EMERGENCY LIGHT AND INDICATORS WILL NOT TURN ON AT THIS TIME.

STEP 6: COMPLETE THE INSTALLATION

- Energize the AC supply. The Status Indicator will illuminate. Refer to the operation information below for more information about the Status Indicator.
- Normally-ON fixtures shall be ON, Normally-OFF shall be OFF. Switched Emergency Fixtures shall be ON only when the switch is in the ON position.
- Manually test the unit by pressing the test switch for 1 second and then release it. (Refer to "MANUAL TEST" on the page 4).
- If status LED is not green, reset the system. (Refer to "SYSTEM RESET" on page 4).
- Properly re-install the cover of the Mini Inverter using all the original hardware.

WIRING FOR NEXUS® (OPTION)

- Route the NEXUS® data cables in the unit and strip one inch (25mm) of the double insulation. The two cables are identical and both contain 2 wires of different colors: color A and color B.
- Gather the color A wire from each cable, and connect them to the same pole on the terminal block. Gather the color B wire from each cable, and connect them to the other pole on the terminal block. The result must be 2 wires of the same color in each pole on the terminal block. See Figure on side.
- Leave a minimum of one inch (25mm) between the live voltage cabling and the unsheathed low voltage data cabling.

NOTE: NO WIRING IS REQUIRED FOR THE NEXUS® WIRELESS VERSION.

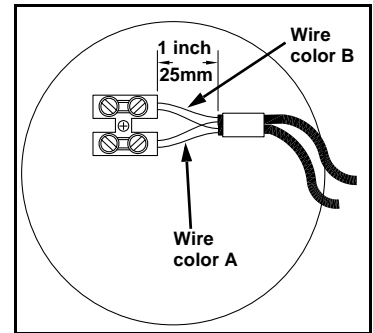

MANUAL TEST

A manual test is initiated once the test switch is pressed for 1 second and then released. The Status Indicator will start flashing green. All normally-ON lamps (switched or unswitched) will turn ON. All normally-off lamps shall also be ON. After 1 minute, the test will stop and all lamps will revert to their normal operating mode.

At the end of the 1-minute test, the unit will revert to recharge mode. The status indicator will be steady ON green if no fault has been detected. If a fault is detected, please refer to the FEATURES AND OPTIONS instructions on pages 8-9 for more details on the diagnostics and auto test features.

Allow the batteries to charge for a minimum of 48 hours after installation or power failure before conducting a 90-minute discharge test. The Life Safety Code and the Authorities Having Jurisdiction require that the 90-minute discharge test be performed on an annual basis.

SYSTEM RESET

Resetting the system:

Depending on the sequence of installation, some units may require a system reset. To reset the system, press the test switch for 6 seconds.

MAINTENANCE

BATTERY: The batteries supplied in this equipment are high quality maintenance-free Valve Regulated Lead Acid design. They require no maintenance and, when installed in an ambient temperature of 20° to 30° C (68° to 86° F), their life expectancy is 8 to 10 years.

However, as stated above, the equipment must be tested for a minimum of 90 minutes once per year. When the batteries will no longer operate the load for 90 minutes, they must be replaced. Replace only with manufacturer supplied parts. Properly dispose of or recycle the Lead-Acid battery.

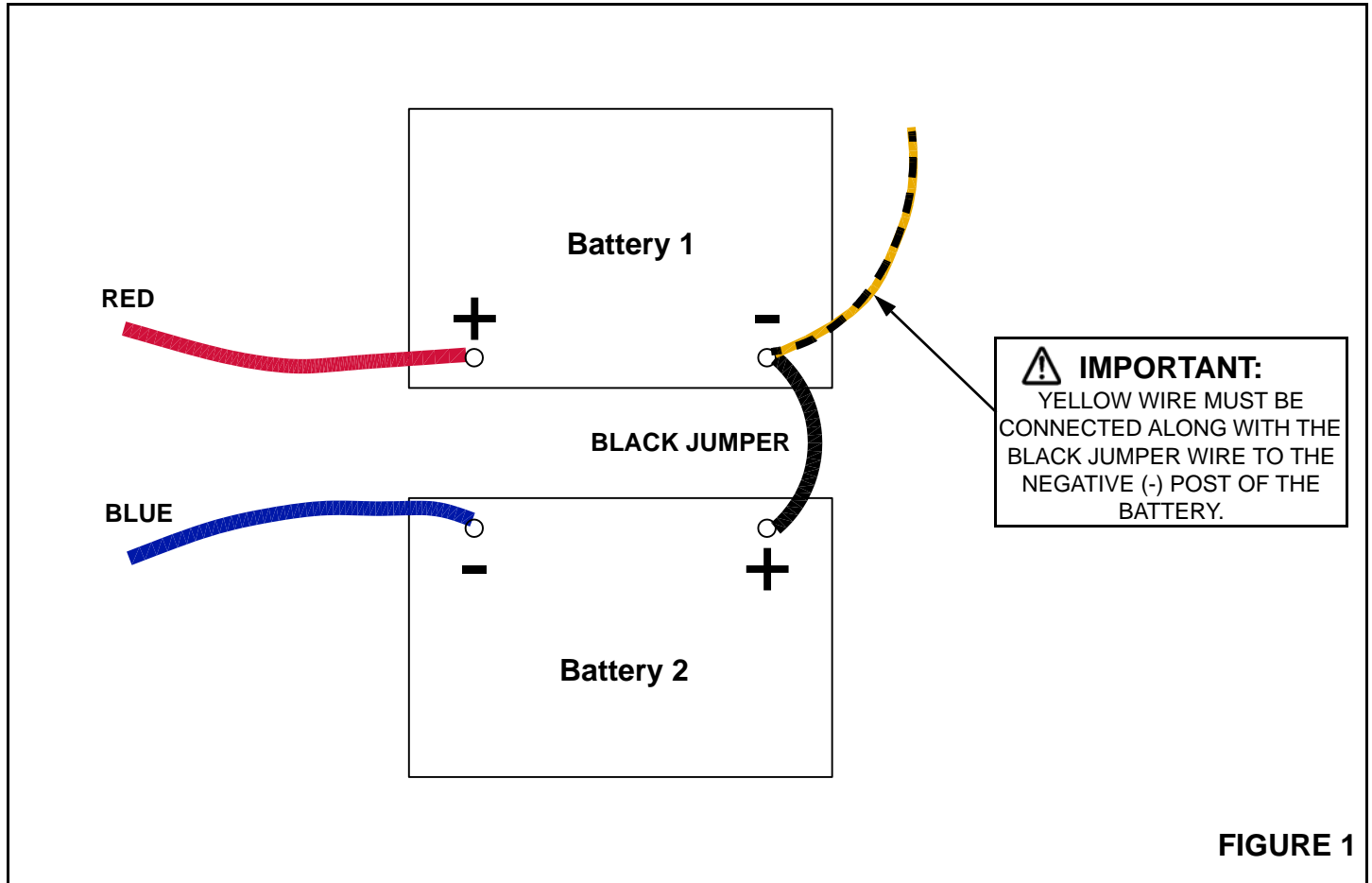

NOTE: THE FOLLOWING WIRING DIAGRAMS HAVE BEEN SIMPLIFIED FOR CLARITY. ACTUAL POSITION OF COMPONENTS WILL VARY.

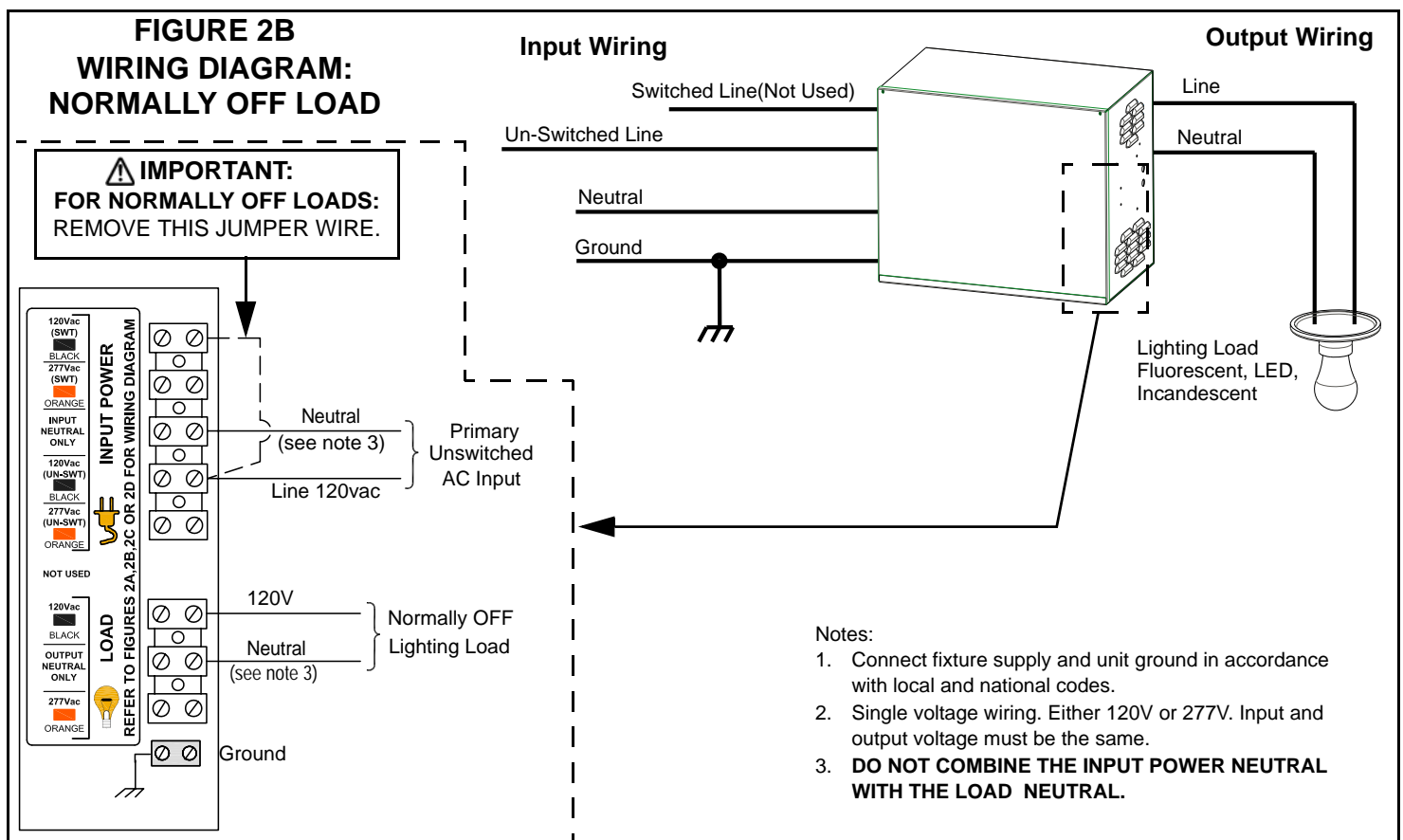
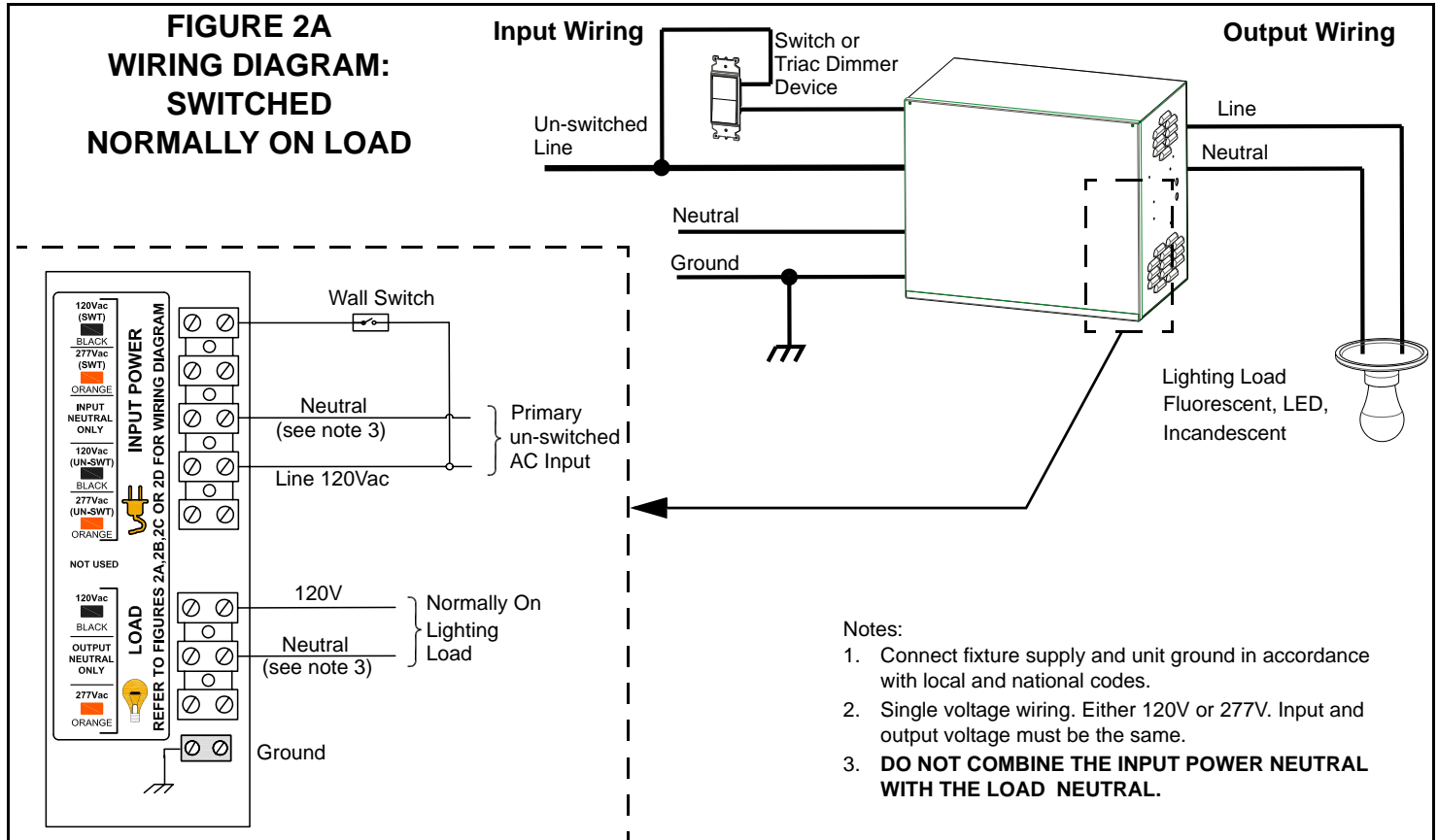

**FIGURE 2C
WIRING DIAGRAM:
UN-SWITCHED
NORMALLY ON LOAD**

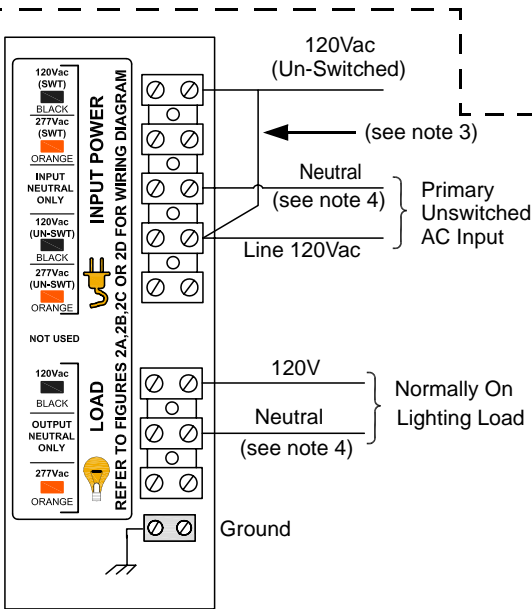

Input Wiring

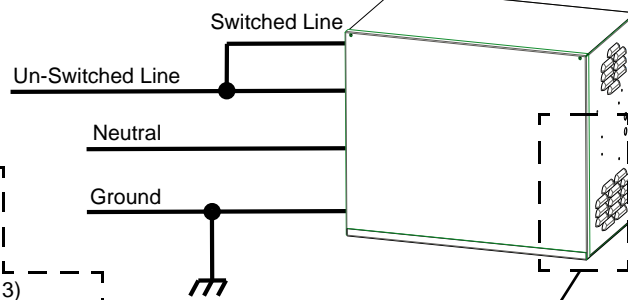

Output Wiring

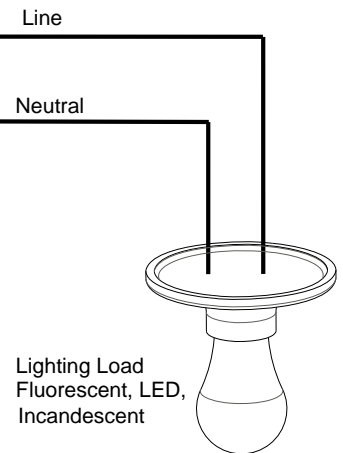

Notes:

1. Connect fixture supply and unit ground in accordance with local and national codes.
2. Single voltage wiring. Either 120V or 277V. Input and output voltage must be the same.
3. Unit jumper wire is preset for 120Vac. If the unit is to be wired for 277Vac, remove the jumper wire from the 120Vac INPUT POWER terminals and reinstall the jumper wire into the 277Vac INPUT POWER terminals.
4. **DO NOT COMBINE THE INPUT POWER NEUTRAL WITH THE LOAD NEUTRAL.**

**FIGURE 2D
WIRING DIAGRAM:
UN-SWITCHED
NORMALLY ON LOAD
WITH LCO.
(REFER TO FIGURE 5)**

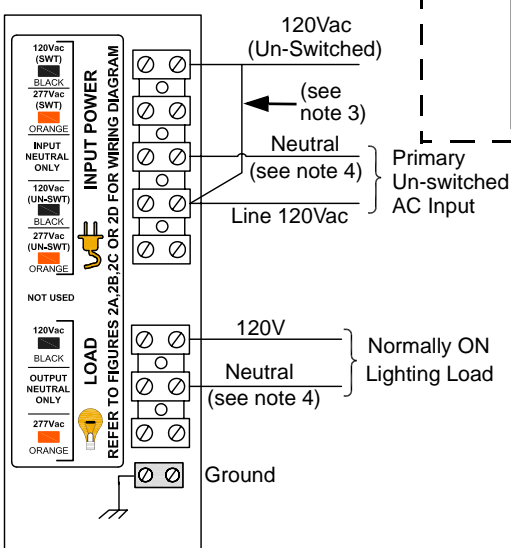

Input Wiring

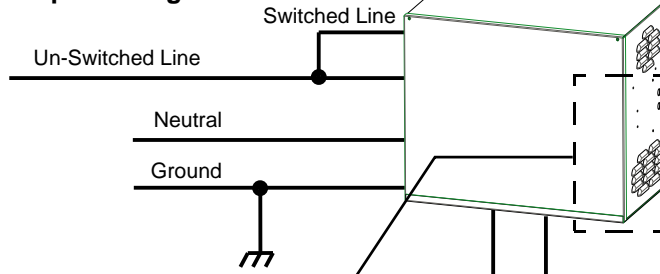

Output Wiring

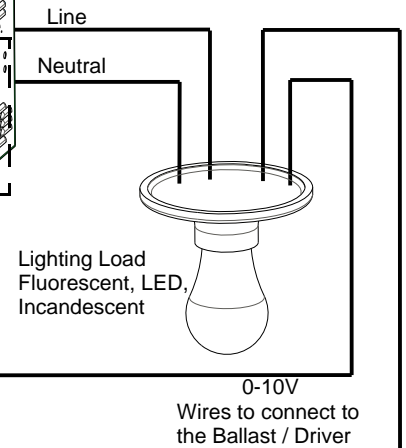

Notes:

1. Connect fixture supply and unit ground in accordance with local and national codes.
2. Single voltage wiring. Either 120V or 277V. Input and output voltage must be the same.
3. Unit jumper wire is preset for 120Vac. If the unit is to be wired for 277Vac, remove the jumper wire from the 120Vac INPUT POWER terminals and reinstall the jumper wire into the 277Vac INPUT POWER terminals.
4. **DO NOT COMBINE THE INPUT POWER NEUTRAL WITH THE LOAD NEUTRAL.**

FEATURES AND OPTIONS

SYSTEM OPERATION

- The diagnostic/charger is a self-contained, fully automatic microcontroller-based system.
- Once the installation is complete, it is not necessary to have the AC power energized. Only the battery needs to be connected. The unit goes directly into lockout mode and waits for AC power to be restored.

1. ALARM SILENCE / MANUAL TEST / SYSTEM INITIALIZATION

- Alarms are silenced by pushing the “TEST” switch less than one half second. Alarm indication can only be silenced after correcting the fault or by re-initializing the system.
- Manual forced tests are initiated by pushing and holding the “TEST” switch more than one second. The 1-minute test will start.
- System initialization is done by holding the “TEST” switch for at least 6 seconds.

2. DIAGNOSTIC AND NEXUS® (OPTION)

If the audible alarm has been activated, any fault condition will produce an audible warning that consists of an intermittent beep: one second on, one second off.

Refer to figure 3 for two lists of possible conditions.

a. BATTERY DISCONNECT / INVERTER FAILURE

The status indicator displays a steady red LED if the battery circuit is open or shorted, or if there is an Inverter failure.

b. BATTERY FAILURE

The status indicator displays 1 red blink and a pause of 5 seconds if an incorrect battery is installed (e.g. 12V battery on a 6V system), or if the battery has failed a timed or forced test (reached LVD level before the end of the test).

c. CHARGER MONITORING

The status indicator displays 2 red blinks and a pause of 4 seconds if the charging current does not fall within limits corresponding to the charger command state.

d. LIGHTING LOAD CAPTURE SEQUENCE

The capture sequence is initiated only by a reset of the system. This is done by holding the “TEST” switch for at least 6 seconds. The reset also initializes the main counter. This renewal takes place to compensate for system variations when the unit ages. Renewal is not allowed if there is a lighting load failure alarm. This is not applicable for units with no auto-test option.

e. SERVER FAILURE

The Nexus server (controller or PC) is no longer communicating with the RF unit’s modem. To solve this issue, you need to verify if the Nexus server is up and running. If it is up and running, check to see if other surrounding emergency lighting units are not powered. If they are powered off, they will prevent the unit in question to communicate with the modem. Otherwise simply reset the modem.

f. BLINK MODE

A “Blink mode” signal was sent from the Nexus server (controller or PC) to the emergency lighting unit. To stop the “Blink mode”, you need to access the Nexus server and execute a stop blink mode operation.

g. NOT COMMISSIONED

The unit was not commissioned and therefore not registered in the Nexus server. Once the unit is commissioned, the auto-test will be disabled and the LED will show a steady green for 10 seconds and steady orange for 1 second.

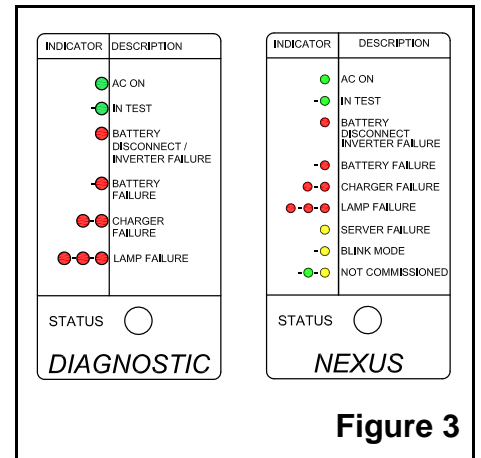

Figure 3

To cancel a fault condition, after applying all corrective actions, simply reset the unit.

*Refer to Nexus® installation addendum for more details.

⚠ IMPORTANT: Reset the system whenever you add or change the lighting load. To reset the system, press the test switch for 6 seconds.

3. AUTOMATIC UNIT TEST (30-DAY TEST)

Every 30 days, while in charging mode, the sequence generator will generate a command to energize the transfer on the emergency lighting circuit for a variable test period depending on the yearly sequence.

	US (MIN)
Monthly test	1
6 month test	30
12 month test	90

NOTE: AUTO-TESTING IS NOT PROVIDED IN SOME UNITS. REFER TO FEATURE 8.

- If the battery fails to complete the discharge test, the charger will display a battery failure and the test will abort.
- The 30-day automatic test sequence is reset every time the lighting load is turned on, including the manual test.

4. LIGHTING LOAD TESTING

The test is fully automatic. To maintain accurate data, these 2 conditions must be met prior to acquiring values from a connected and functional lighting load:

- The battery has to be at or near full power. The program will delay data capture for a minimum of 48 hours following any discharge or reset.
- The charger will also wait to be in hysteresis mode (charger cycling on/off).

⚠ IMPORTANT: Must install a minimum lamp load equivalent to 10% of the rated capacity of the unit.
 Example: 72.0W/VA for a 720W inverter unit.

5. AUDIBLE ALARM (BUZZER)

This option can be activated or de-activated in the field. Refer to Figure 4.

To select the audible alarm option:

- Remove all power sources to the board (AC and battery).
- With long-nose pliers, pull on the shunt (little black box) until it is free from the pins.
- Put the shunt back in place according to the option selection.
- Reconnect AC power and the battery.

6. SERVICE ALARM (OPTION)

Not available for this unit.

7. LIGHTING CONTROL OVERRIDE

This feature is used with lighting loads equipped with low voltage dimming control. The dimming function must be disabled during a power failure in order for the load to provide a 100% level of lighting.

The circuit consists of a single-pole dry-contact relay that is normally closed in stand-by operation. In emergency mode (power failure) the relay contacts open and disconnect the dimming signal from the lighting load, allowing the load to operate at 100% light level.

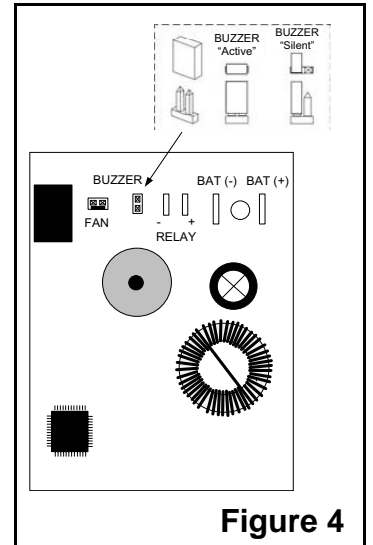

Figure 4

i IMPORTANT: Only one control signal can be handled by one LCO module. Multi control signals require one LCO per control signal. Consult customer service if there is more than one Lighting Control signal to be overridden.

INSTALLATION:

1. Locate the Lighting Control signal cable pair.
2. Cut, strip and extend one wire only, of the Lighting Control signal cable.
3. Connect to the terminal block marked "LIGHTING CONTROL OVERRIDE" as shown in the wiring diagram below.

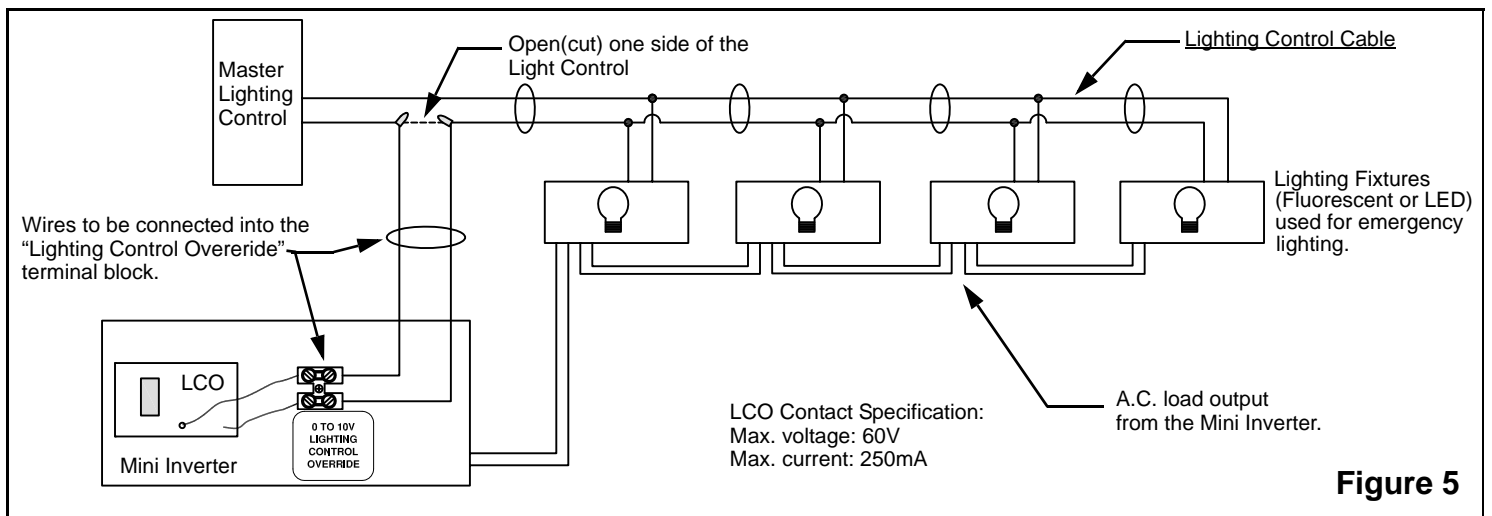



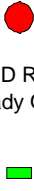



Figure 5





8. UNITS WITH NO AUTO-TEST (OPTION)

This equipment is not self-testing in conformance with the Life Safety Code, ANSI/NFPA 101.

TROUBLESHOOTING GUIDE (PAGE 1 OF 2)

STATUS INDICATOR (LED)	TROUBLESHOOTING GUIDE		
	SYMPTOMS	PROBLEM	CORRECTIVE ACTION
 LED GREEN ON Steady, not flashing	Lamp load is on	None if unit is in normally on mode	Unit is operating correctly
	Lamp load is off	None if unit is in normally off mode	Unit is operating correctly
	Lamp load is OFF, but the unit is in normally on mode	The fuses are burnt	Replace the fuses after verifying that there is no short circuit in the load
	-Lamp load is OFF (if installation is normally OFF) -Lamp load is ON (if installation is normally ON)	Power at primary AC input + battery discharged (at LVD) + no reaction with test button	- Remove the primary AC input + disconnect the battery + wait minimum 10 seconds - connect the battery + connect the primary AC input => the unit will restart - if the unit did not restart + call technical support.
 LED flashing GREEN/ORANGE	Lamp load is ON	None if unit is in normally on mode +Nexus option	Unit is operating correctly. Unit is not commissioned to the Nexus system
	Lamp load is OFF	None if unit is in normally off mode +Nexus option	Unit is operating correctly. Unit is not commissioned to the Nexus system
 LED flashing GREEN/OFF	Lamp load is ON	None the unit is in test mode or is sampling load	Unit is operating correctly
	Lamp load is OFF	The output fuse is burnt	Replace the fuses after verifying that there is no short circuit in the load
 LED steady OFF, not flashing	Lamp load is ON	No power at primary AC input + in emergency mode	Check the circuit breaker panel
	Lamp load is OFF	No power at primary AC input + emergency mode stop (battery discharged)	Check the circuit breaker panel
	-Lamp load is OFF (if installation is normally OFF) -Lamp load is ON (if installation is normally ON)	Power at primary AC input + battery discharged (at LVD) + no reaction with test button	- Remove the primary AC input + disconnect the battery + wait minimum 10 seconds - connect the battery + connect the primary AC input => the unit will restart - if the unit did not restart, call for technical support at 1-(888)-552-6467.
 LED RED steady ON + GREEN LED on PCBA charger board steady ON	Inverter Error	In emergency or in test, no output (Inverter switch OFF)	Check the inverter ON/OFF switch => Turn it on. Switch is located on the right end of the inverter module.
		In emergency or in test, no output (Inverter Failure)	Check the inverter control RJ12/RJ50 cable
		In emergency or in test, output OK (Inverter Sensing defect)	Check if the yellow wire is connected. Refer to figure 1.
		In emergency or in test, no output (Inverter Failure)	Reset the system(see page 4) and if the result is the same, replace the inverter module
		Over temperature in emergency or in test	- Verify if the LED Over Temp/Fault is ON on the inverter - Verify if fan is blocked or not working
		Over load in emergency or in test	- Verify if the LED Overload/Fault is ON on the inverter - Verify if too many loads are connected to the inverter
 LED RED steady ON	Battery Disconnect Error	No battery installed in the unit	Install the battery following the installation guide
		The 12V battery sensing not connected	Check if the yellow wire is connected. Refer to figure 1.

TROUBLESHOOTING GUIDE (PAGE 2 OF 2)

 LED Flashing RED 1 times every 6 seconds	Battery Failure Error	The battery did not last enough for a manual or monthly test	Replace the batteries
		The battery did not last enough for an annual test	Replace the batteries
		Battery fail in charge	Replace the batteries
 LED Flashing RED 2 times every 6 seconds	Charger Failure Error	Charger not working	Reset the unit (see page 4) and if the same error is displayed, replace the charger board
 LED Flashing RED 3 times every 6 seconds	Lamp Failure Error	Lost 10% or more if initial lamp loading is lost	Replace the bad lamp and reset the unit
	-Lamp Failure Error -No output voltage	The fuses are burnt	Replace the fuses after verifying that there is no short circuit in the load
		Loose connection to the terminal block	Verify that all wires are well connected to the terminal block
 LED AMBER (ORANGE) steady On	Network server down	The Nexus modem is no longer sending a signal to the Nexus server.	See Nexus manual system
 LED flashing between AMBER/OFF	Wink mode	The unit is in yellow blink mode	Stop the wink mode by sending a message from the Nexus server or reset the unit (see page 4).

CONTACT CUSTOMER SERVICE FOR REPLACEMENT PARTS.
SERVICING MUST BE PERFORMED BY QUALIFIED PERSONNEL.
Consult Customer Service for current warranty information.

All information and specifications contained in these instructions are subject to change
due to engineer design, errors and omissions.
© 2014 Thomas & Betts Limited. All rights reserved