

NYC Approved LED Battery units

This series is offered where an attractive conventional emergency lighting unit is required



Ideal for spaces that require a highly efficient LED emergency lighting unit with 2 or 3 lighting heads and a steel enclosure. Each lamp head provides 150 lumens

UL 924 listed

- Complies with NEC, Life Safety Code and OSHA

Fully automated and easy to install

Sealed maintenance-free battery

- 3.6V nickel-cadmium

Standard features

• Unit data

Constructed of 20 gauge heavy-duty steel and a durable white powder-coat finish. The NYLED-2/3 unit is furnished with 2 or 3 glare free heads (1.5W LED); the NYLED-2 unit is furnished with 2 (1.5W) LED heads

• Electrical

- 120V/277V Input standard
- Low voltage disconnect prevents over discharge of battery
- Brownout protection standard

• Reliability

This series has a 3 year full warranty (excluding lamps and fuses)

Dimensions

Dimensions are approximate and subject to change.

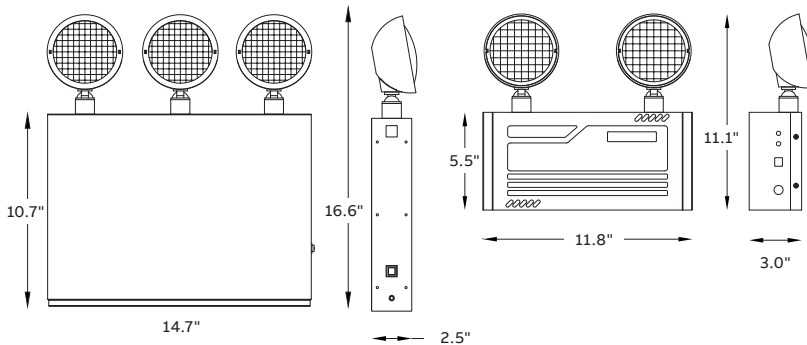

Unit selection chart

Series	D.C. Voltage	Number of heads	Color
NYLED-2-N	3.6V	2 X 1.5W LED lamps	White
NYLED-2/3-N	3.6V	3 X 1.5W LED lamps	White

Example: NYLED-2