

EMIU 400W - 4 Option Mini Inverter INTERRUPTIBLE EMERGENCY LIGHTING UNIT INVERTER INSTRUCTION MANUAL

IMPORTANT SAFEGUARDS

When using electrical equipment, basic safety precautions should always be followed, including the following:

READ THIS MANUAL AND FOLLOW ALL SAFETY INSTRUCTIONS THOROUGHLY BEFORE OPERATING THE EMIU INVERTER SYSTEM

i BEFORE CONTACTING TECHNICAL SUPPORT MAKE SURE TO FOLLOW ALL STEPS IN SEQUENCE AND REFER TO THE TROUBLESHOOTING GUIDE INCLUDED IN THIS MANUAL.

SAVE THESE INSTRUCTIONS

1. Install in accordance with the National Electrical Code and local regulations.
2. The **EMIU** contains potentially hazardous voltages. Installation, maintenance and service work should be performed by qualified and trained personnel.
3. Units to be installed only as per configuration described in this instruction manual.
4. Electricians and end-users need to ensure product system compatibility before final installation.
5. The AC voltage rating of this equipment is specified on the product label. Do not connect the **EMIU** equipment to any other voltage.
6. All unused wires must be capped to prevent shorting.
7. The **EMIU** should be mounted securely and in locations and at heights where it will not be readily subjected to tampering by unauthorized personnel.
8. The use of accessory equipment and replacement parts not recommended by manufacturer may cause an unsafe condition and will void the warranty.
9. Do not mount near gas or electric heaters.
10. Do not let power supply cords touch hot surfaces.
11. Do not use this equipment for other than its intended use.
12. DO NOT USE OUTDOORS.
13. The **EMIU** uses sealed valve regulated lead acid batteries. Batteries can be punctured if not handled properly, therefore use caution when servicing batteries. In the event battery acid comes in contact with eyes or skin, flush with fresh water and consult a physician immediately.

MODEL NUMBER	AC SPECS		EMERGENCY POWER AVAILABLE FOR LOAD				APPROX. WEIGHT
			90 MIN	2H	3H	4H	
EMIU 400 - 4 option	120/277 VAC, 60Hz	4.6 / 2.0 Amps	400W	300W	200W	150W	150lbs.

NOTE: At 120Vac, unit is rated at power factor 0.8. For loads having a power factor below 0.8, unit capacity needs to be derated. At 277Vac, unit is rated at 0.9 power factor. For loads having a power factor below 0.9, unit capacity needs to be derated.

WARRANTY

All ABB inverter products receive 100% quality inspection before shipment to ensure proper and satisfactory operation. When operated under normal conditions, ABB inverter products will provide years of dependable service. This unit is backed by a 3-7 year warranty. The unit is covered by a complete 3-year warranty against defects in material or workmanship, and a 7-year pro-rata battery warranty.

 **WARNING:** DE-ENERGIZE THE CIRCUIT BEFORE INSTALLATION OR MAINTENANCE.

 **WARNING:** DO NOT ENERGIZE THE CIRCUIT UNTIL ALL STEPS HAVE BEEN SUCCESSFULLY COMPLETED.

 **WARNING:** ALWAYS TURN OFF THE INVERTER MODULE AND THE AC SUPPLY TO THE EQUIPMENT AND DISCONNECT THE BATTERY BEFORE SERVICING. ONLY QUALIFIED SERVICE TECHNICIANS SHOULD SERVICE THIS EQUIPMENT. THE USE OF PARTS SUPPLIED BY OTHER THAN THE MANUFACTURER MAY RESULT IN AN UNSAFE CONDITION OR EQUIPMENT FAILURE AND WILL VOID THE WARRANTY.

 **WARNING:** DO NOT CONNECT THE BATTERY(IES) UNTIL YOU ARE PREPARED TO START-UP THE UNIT PERMANENTLY. CONNECTING THE BATTERIES WITH THE UNIT OFF MAY DRAIN THE BATTERIES TO THE POINT THAT YOU WILL NOT BE ABLE TO START-UP THE UNIT.

 **WARNING:** FAILURE TO CONNECT THE BATTERIES PROPERLY MAY RESULT IN EQUIPMENT FAILURE OR AN UNSAFE CONDITION AND WILL VOID THE WARRANTY. A SMALL SPARK MAY OCCUR WHEN CONNECTING TO THE BATTERY WIRES. THIS IS NORMAL AND IS CAUSED BY LARGE CAPACITORS CONTAINED IN THE MINI INVERTER BEING CHARGED.

 **CAUTION:** BATTERIES ARE SHIPPED SEPARATELY. PLACE THEM IN A LOCATION AWAY FROM THE WORK AREA TO AVOID DAMAGE UNTIL THEY ARE TO BE INSTALLED.

 **CAUTION:** THIS UNIT PROVIDES MORE THAN ONE POWER SUPPLY OUTPUT SOURCE. TO REDUCE THE RISK OF ELECTRICAL SHOCK WHEN SERVICING, DISCONNECT BOTH NORMAL AND EMERGENCY SOURCES BY TURNING OFF THE A.C. BRANCH CIRCUIT AND BY DISCONNECTING THE BATTERY.

 **CAUTION:** ONLY ONE VOLTAGE IS ALLOWED (120V OR 277V). CONNECTION TO MORE THAN ONE VOLTAGE MAY RESULT IN EQUIPMENT FAILURE AND VOID THE WARRANTY.

 **CAUTION:** THE MINI INVERTER HAS A SELF-TEST FEATURE AND CAN ENTER IN SELF-TEST MODE (MONTHLY, BIANNUAL OR ANNUAL) AT ANY TIME. WHEN THIS OCCURS, POWER WILL BE AVAILABLE AT THE OUTPUT OF THE MINI INVERTER, EVEN IF THE LATTER WAS CONFIGURED FOR NORMALLY-OFF OPERATION. ALWAYS TURN OFF THE INVERTER MODULE INSIDE THE MINI INVERTER BEFORE WORKING WITH THE WIRING SYSTEM OF THE EMERGENCY LIGHTING SYSTEM.

 **IMPORTANT:** FOLLOW THE APPROPRIATE WIRING DIAGRAMS. DO NOT CONNECT THE "INPUT POWER" NEUTRAL TO THE "LOAD" NEUTRAL. FAILURE TO COMPLY WITH THIS DIRECTIVE MAY RESULT IN EQUIPMENT FAILURE AND VOID THE WARRANTY.

 **IMPORTANT:** FOR NORMALLY OFF LOAD: REMOVE THE JUMPER WIRE BEFORE WIRING THE UNIT. REFER TO THE WIRING DIAGRAMS.

 **IMPORTANT:** ALL 0-10V LIGHTING CONTROL SIGNAL SHOULD BE RUN AS CLASS 2 (LOW VOLTAGE) WIRING. NEVER RUN LINE VOLTAGE AND LOW VOLTAGE WIRING IN THE SAME CONDUIT AND PROVIDE SUFFICIENT SEPARATION IN RACEWAY INSTALLATIONS. RUNNING THE 0-10 V SIGNAL AS CLASS 1 (LINE VOLTAGE) WIRING INTRODUCES SOME CONCERNS, INCLUDING NOISE/ INTERFERENCE CAUSED BY COUPLING BETWEEN THE LINE VOLTAGE AND LOW-VOLTAGE WIRES. THIS NOISE / INTERFERENCE CAN CAUSE A VOLTAGE FLUCTUATION ON THE 0-10 V WIRES WHICH CAN CREATE A DIFFERENCE BETWEEN THE LIGHT LEVEL REQUESTED BY THE CONTROL AND THE LIGHT LEVEL SIGNAL BEING RECEIVED BY THE BALLAST / DRIVER.

INSTALLATION

STEP 1: MOUNTING THE MINI INVERTER TO WALL (SEE FIGURE 1)

- a. Remove the front cover of the Mini Inverter by removing the two screws at the top of the cover.
- b. Extend the unswitched, properly-rated voltage AC supply and remote fixture wires to the installation area.
- c. Orient cabinet to ensure clearance is 3.5 inches on either side of the Mini Inverter and 42 inches on the front. No clearance is required on the bottom of the unit. For units equipped with optional wireless Nexus, a clearance of 6 inches is required on top to allow for the protruding antenna. For units without wireless Nexus, no clearance is required on the top.
- d. Use keyhole slots at the rear of the unit and mount the Mini Inverter securely to the wall.



WARNING:

THE MINI INVERTER MUST BE MOUNTED SECURELY USING A 1/4" (MIN) SCREW AND FLAT WASHER FOR EVERY KEYHOLE. THE MOUNTING SURFACE MUST ALSO BE SUFFICIENTLY REINFORCED TO ACCOMODATE THE WEIGHT LISTED (SEE PAGE 1). FAILURE TO SECURE THE UNIT SUFFICIENTLY CAN DAMAGE THE EQUIPMENT AND/OR CAUSE SERIOUS INJURY.

- e. Connect the conduit containing the AC supply and remote fixture leads to the Mini Inverter. Use the provided knock-outs on the side of the Mini Inverter for connecting the incoming wires.
- f. Install the batteries at this time, but do not connect the battery leads until other wiring is completed.



CAUTION:

CABINET IS HEAVY AND AWKWARD TO LIFT. MAKE PROPER PROVISIONS TO ENSURE SAFETY OF INSTALLERS.

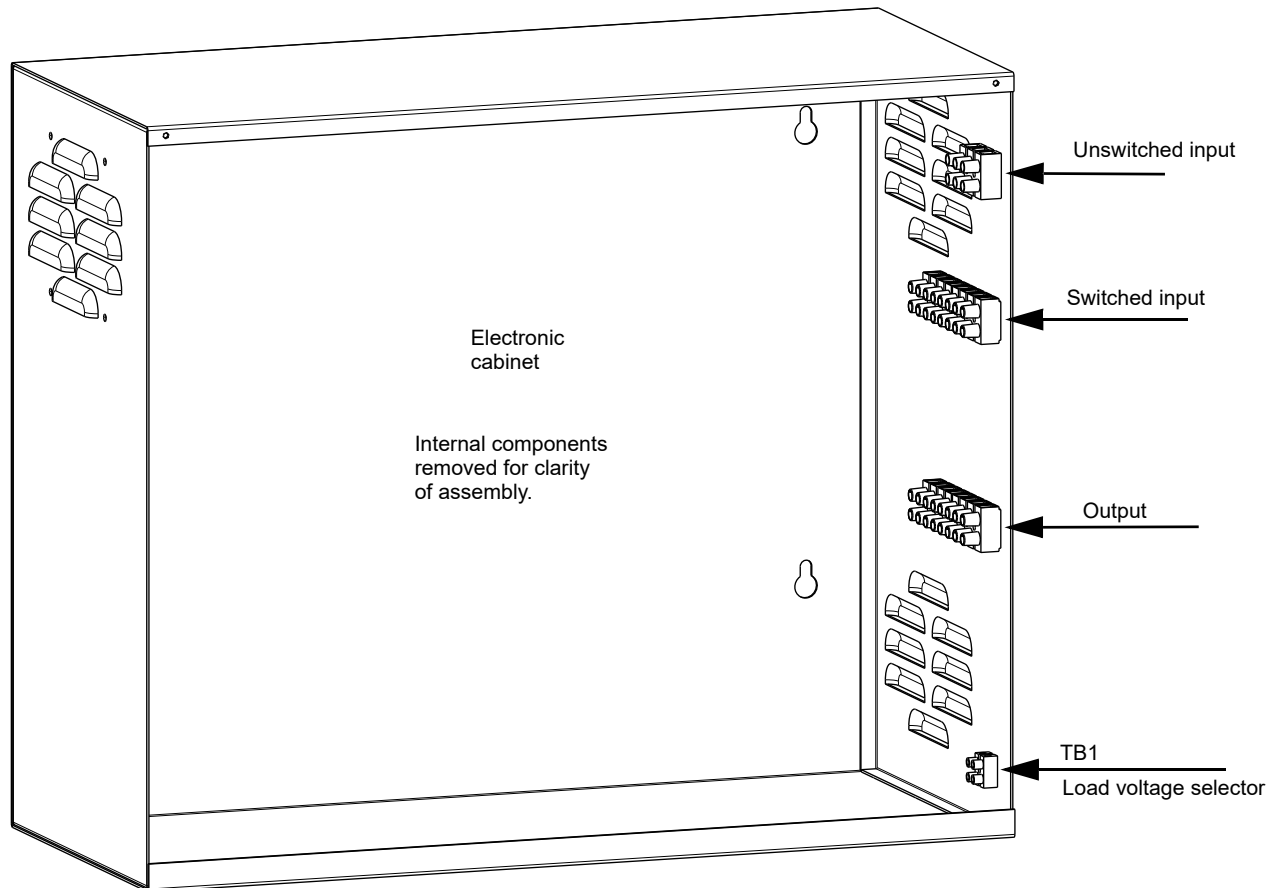

FIGURE 1

ELECTRICAL SINGLE LINE DIAGRAM FOR EMIU 400W WITH 4 CIRCUITS (-4 OPTION)

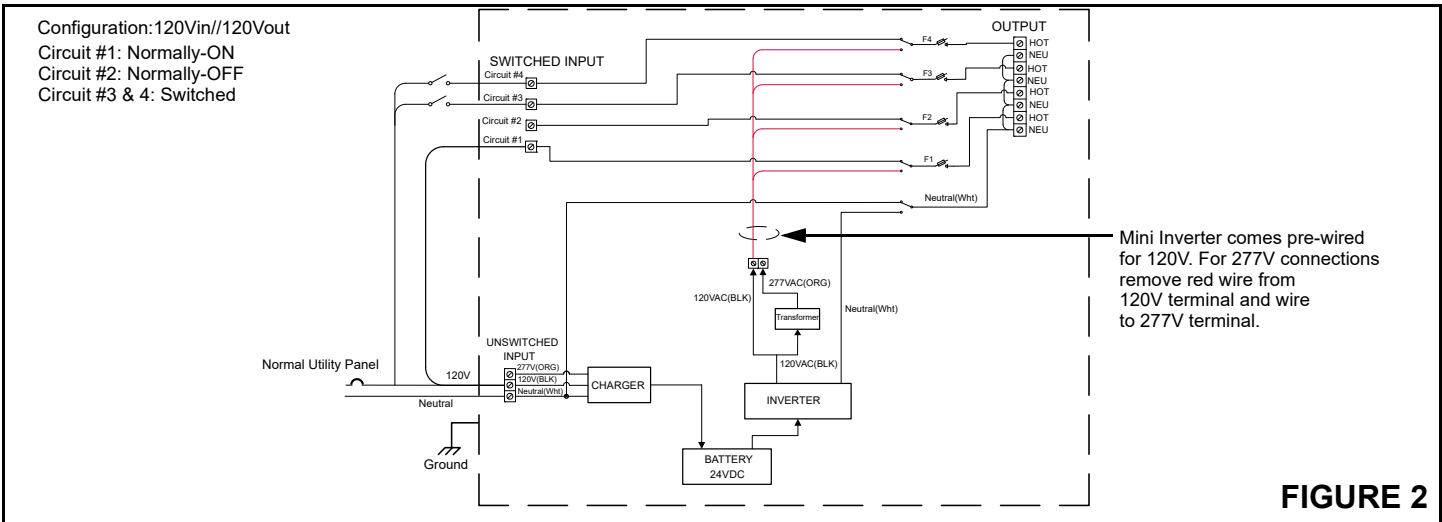

FIGURE 2

- Mini Inverter with option -4 can control four individual circuits (see figure 2).
- Unit can be configured for either 120V in // 120V out or 277V in // 277V out.
- Power applied to the UNSWITCHED INPUT charges the batteries.
- The four SWITCHED INPUTS can each be configured to operate Normally-On, Normally-Off or Switched loads.
- Power supplied to the switched inputs must be fed from the same branch circuit as the unswitched input (see figure 2).**
- Unit is shipped from factory pre-set for 120V in // 120V out and configured for Normally-On load operation (see figure 2). This configuration can be changed to fulfill customer's application.
- In Normal AC mode, the load connected at the output is powered by the power applied to the SWITCHED INPUT.
- In Emergency mode, the load is powered by the battery through the inverter. The inverter converts the battery DC power to AC power.

STEP 2: CONFIGURATION OF OUTPUT VOLTAGE (SEE FIGURE 2 AND 3)

- Output voltage of the Mini Inverter with option 4 can be configured for either 120VAC or 277VAC.
- Identify the terminal block TB1 located on the right hand side of the cabinet.

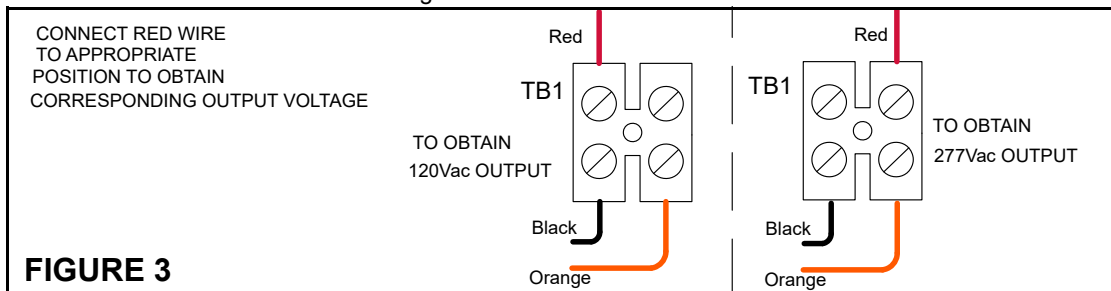

FIGURE 3

- Position of the red wire determines the voltage available at the output of the Mini Inverter.
- When the red wire is connected at the left terminal of TB1, the output voltage available will be 120VAC.
- When the red wire is connected on the right terminal of TB1, the output voltage available will be 277VAC.
- Identify the voltage rating of all the loads to be powered by the Mini Inverter.
- If the voltage rating of the loads is 120VAC, connect the red wire to the left terminal of TB1.
- If the voltage rating of the loads is 277VAC, connect the red wire to the right terminal of TB1.

STEP 3: WIRING TO UNSWITCHED INPUT

WARNING: PRIOR TO MAKING ANY WIRING CONNECTIONS TO THE MINI INVERTER, MAKE SURE THE BRANCH CIRCUIT BREAKER FEEDING THE UNIT IS TURNED OFF AT THE SERVICE PANEL.

- Connect the Ground wire to the Ground Bus Bar.
- Identify the terminal block for UNSWITCHED INPUT (figures 6, 7, 8 or 9).
- Connect the NEUTRAL wire to the NEUTRAL position of the UNSWITCHED INPUT terminal block.
- For 120V supply, connect the AC Line wire to the 120V position of the UNSWITCHED INPUT terminal block. For 277V supply, connect the AC Line wire to the 277V position of the UNSWITCHED INPUT terminal block.

STEP 4: WIRING TO SWITCHED INPUT

CAUTION: POWER SUPPLIED TO THE SWITCHED INPUTS MUST BE FED FROM THE SAME BRANCH CIRCUIT AS THE UNSWITCHED INPUT.

The Mini Inverter model with -4 option can be configured for various modes of operation as described below.

- a. **Normally-On Operation** (Refer to Figure 6 for wiring details) - Fixtures remain illuminated in normal AC and emergency modes.
- b. **Normally-Off Operation** (Refer to Figure 7 for wiring details) - Fixtures illuminated only upon loss of utility AC power.
- c. **Switched Load Operation** (Refer to Figure 8 for wiring details) - Fixtures can be externally controlled and will illuminate upon loss of utility AC power regardless of the state of the external control device (switch, motion sensor, dimmer, etc.).
- d. **Combination of Normally-On, Normally-Off and Switched Load Operation** (Refer to Figure 9 for wiring details) - Each circuit in the Mini Inverter with the -4 option can be configured in one of the previously described modes of operation.

Refer to the applicable wiring diagram in figures 6, 7, 8 and 9 to connect the utility AC power and external control devices (where applicable). Perform all wiring procedures in accordance with applicable codes. The unit is shipped configured to operate in Normally-On mode by using an assembled jumper. This jumper can be removed to configure the SWITCHED INPUTS as desired.

Do not connect the load to the Mini Inverter at this point of time.

CAUTION: ALL FOUR SWITCHED INPUTS HAVE BEEN JUMPERED AND IS PRESET FOR 120VAC TO OPERATE NORMALLY ON LOADS. IF THE UNIT IS TO BE WIRED FOR 277VAC, REMOVE THE JUMPER WIRE FROM THE 120VAC INPUT POWER TERMINAL AND REINSTALL THE JUMPER WIRE INTO THE 277VAC INPUT POWER TERMINAL.

CAUTION: IF CONNECTED TO 277V SWITCHED INPUT, USE A 277V RATED SWITCH. FAILURE TO USE THE PROPER VOLTAGE SWITCH MAY RESULT IN SWITCH FAILURE, A SHOCK HAZARD, AN UNSAFE CONDITION AND/OR EQUIPMENT FAILURE.

STEP 5: CONNECT BATTERIES (SEE FIGURE 4)

- a. Position the batteries in the unit.
- b. Refer to figure 4. Connect the RED wire to the positive (+) post of the battery. Connect the BLUE wire to the negative (-) post of the battery. Tighten all bolts to a recommended torque of **78 lbf-in ± 4 lbf-in**.

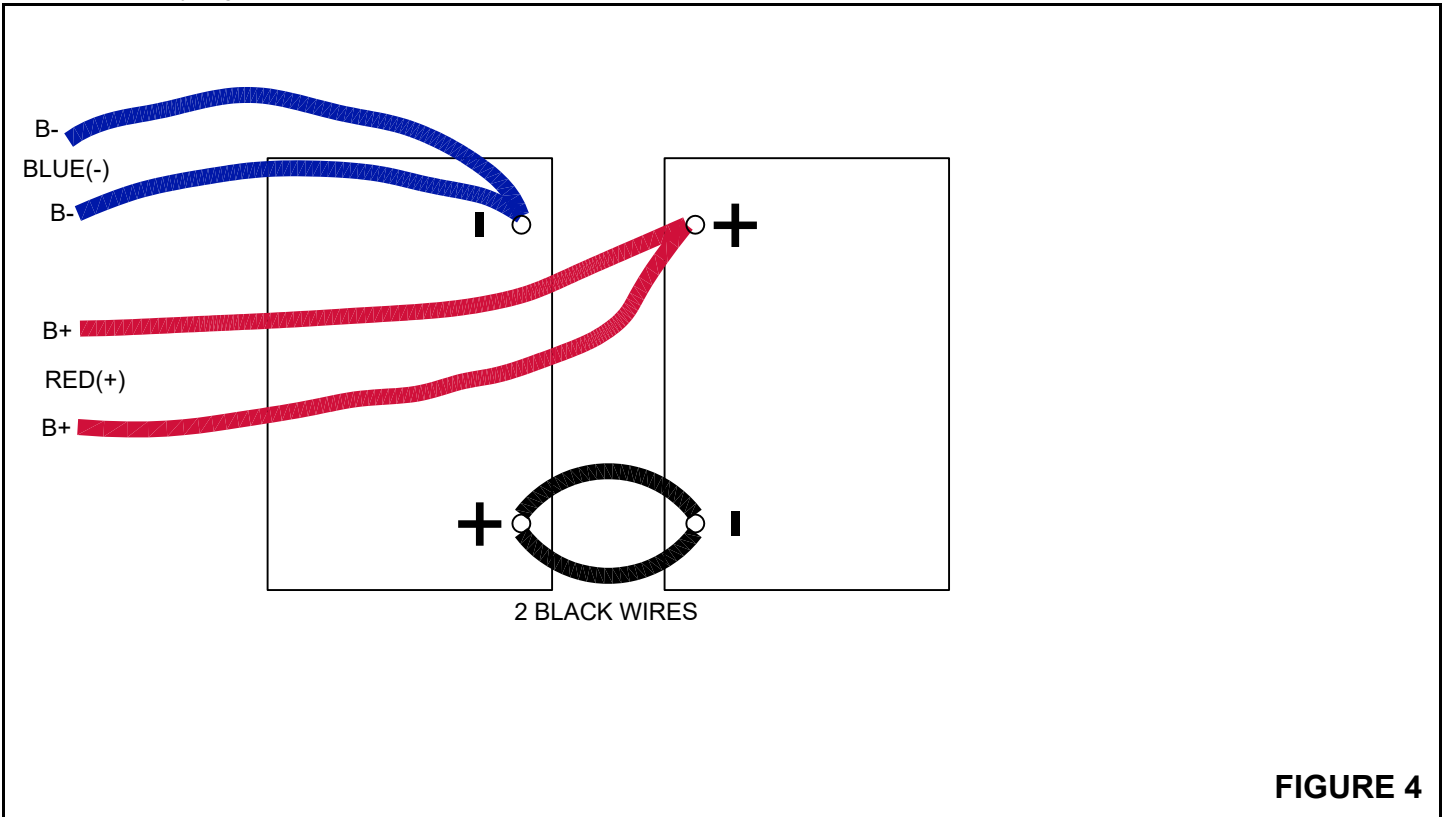

FIGURE 4

STEP 6: START-UP WITH NO LOAD CONNECTED.

- a. Confirm load is not connected.
- b. Follow start-up procedure in Step 7.

STEP 7: START-UP PROCEDURE

- a. Turn on switch located on right hand side of inverter module in the electronic cabinet. Emergency lights and indicator will not illuminate.
- b. Energize AC mains supply. Status Indicator on the left side of electronic cabinet will illuminate. For more information about the Status Indicator, see information section FEATURES AND OPTIONS.
- c. If status LED Indicator is not green, reset the system. (Refer to "SYSTEM RESET" on page 7).
- d. Manually test unit by pressing test switch for 1 second. (Refer to "MANUAL TEST" on the page 7).
- e. Measure and record voltage at the output of circuits 1, 2, 3 and 4.
- f. Confirm measured output voltages match voltage rating of the loads.
- g. Following the 1 minute test, simulate a power outage by turning off the AC mains circuit breaker feeding the Mini Inverter.
- h. Measure and record voltages at the output of circuits 1, 2, 3 and 4.
- i. Confirm measured output voltages match voltage rating of the loads. If voltages do not match, check the wiring or call Technical Support.

STEP 8: SHUT DOWN PROCEDURE.

- a. Turn off switch located on right-hand side of inverter module.
- b. Turn off AC mains circuit breaker in the service panel feeding the Mini Inverter.

STEP 9: CONNECT THE LOAD.

- a. Before proceeding, confirm all circuits are de-energized.
- b. Upon confirmation that measured output voltage of Mini Inverter matches voltage rating of loads, wire load.
- c. Identify output terminal block (refer to figures 6, 7, 8 and 9).
- d. The neutrals of circuit# 1, circuit# 2, circuit# 3 and circuit# 4 are shorted.
- e. Connect Ground wires from loads to Ground Bus Bar.
- f. Connect neutral wires from loads to neutral terminals of output terminal block.
- g. The neutrals of emergency fixtures must be wired to output terminal block.
- h. Do not connect the neutral wire of emergency fixtures to neutral wire of normal non-emergency lighting.
- i. Connect hot wires from emergency lighting loads to the "HOT" terminals of OUTPUT terminal block.

STEP 10: START-UP WITH LOAD CONNECTED.

- a. With loads connected, follow the start-up procedure in Step 7.
- b. Normally-ON fixtures must be ON, Normally-OFF must be OFF. Switched Emergency Fixtures must only be ON when switch is in ON position.
- c. Re-install the cover of the Mini Inverter using original hardware.

NEXUS[®] (OPTION)

Wired:

- a. Route NEXUS[®] data cables into unit and strip one inch (25mm) of the cable insulation. Two cables are identical and contain 2 wires of different colors: color A and color B.
- b. Connect both color "A" wires to the same pole on the terminal block. Connect both color "B" wires to the same pole on the terminal block. The result must be 2 wires of the same color connected to each pole on the terminal block. See Figure 5.
- c. Live voltage cabling and unsheathed low voltage data cabling must be a minimum of one inch (25mm) apart.

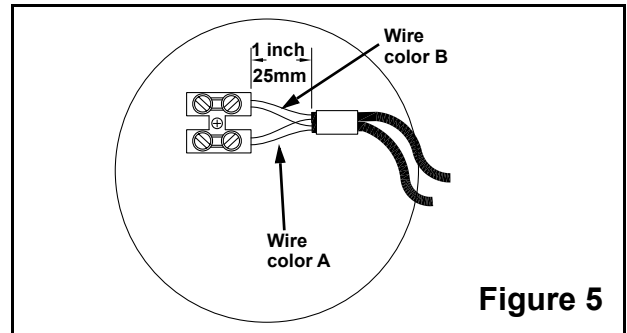

Figure 5

Wireless:

NO WIRING IS REQUIRED FOR THE NEXUS[®] WIRELESS VERSIONS.

See Nexus[®] addendums: 750.1532 and 750.1641 for more information and antenna installation.

See Nexus[®]Pro addendums: 750.1641 and 750.2060 for antenna installation and important information before powering up unit.

MANUAL TEST

Press test switch for 1 second to initiate a 1 minute manual test. Status Indicator will start flashing green. All normally-ON lamps (switched or unswitched) will turn ON. All normally-off lamps shall also be ON. After 1 minute test lamps will revert to their normal operating mode and unit will revert to recharge mode. Status indicator will be steady ON green if no fault has been detected. If a fault is detected, refer to the FEATURES AND OPTIONS instructions on pages 12 to 14 for diagnostics and auto test features.

Allow the batteries to charge for a minimum of 48 hours after installation or power failure before conducting a 90-minute discharge test. The Life Safety Code and the Authorities having Jurisdiction require an annual 90-minute discharge test.

SYSTEM RESET

Resetting the system:

Depending on the sequence of installation, some units may require a system reset. To reset, press and hold test switch on left side of unit for 6 seconds.

MAINTENANCE

BATTERY:

The batteries supplied in this equipment are high quality maintenance-free Valve Regulated Lead Acid design.

When installed in an ambient temperature of 25° C (77° F), their life expectancy is 8 to 10 years.

When batteries will no longer operate the load for 90 minutes, they must be replaced. Replace only with manufacturer supplied parts.

Properly dispose of or recycle the Lead-Acid battery.

NORMALLY-ON OPERATION

All four(4) circuits configured to operate in Normally-On mode.

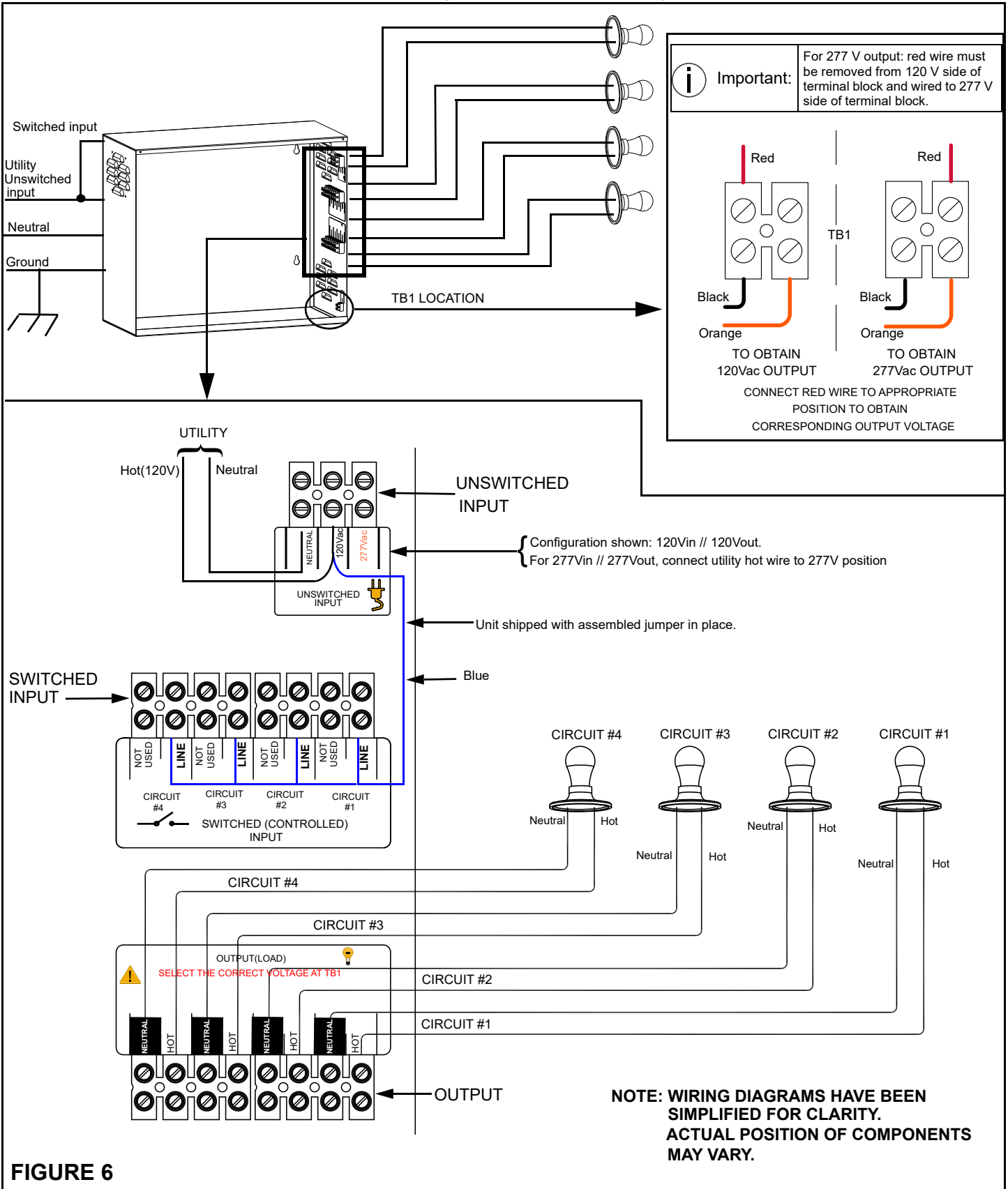

FIGURE 6

NORMALLY-OFF OPERATION

All four(4) circuits configured to operate in Normally-Off mode.

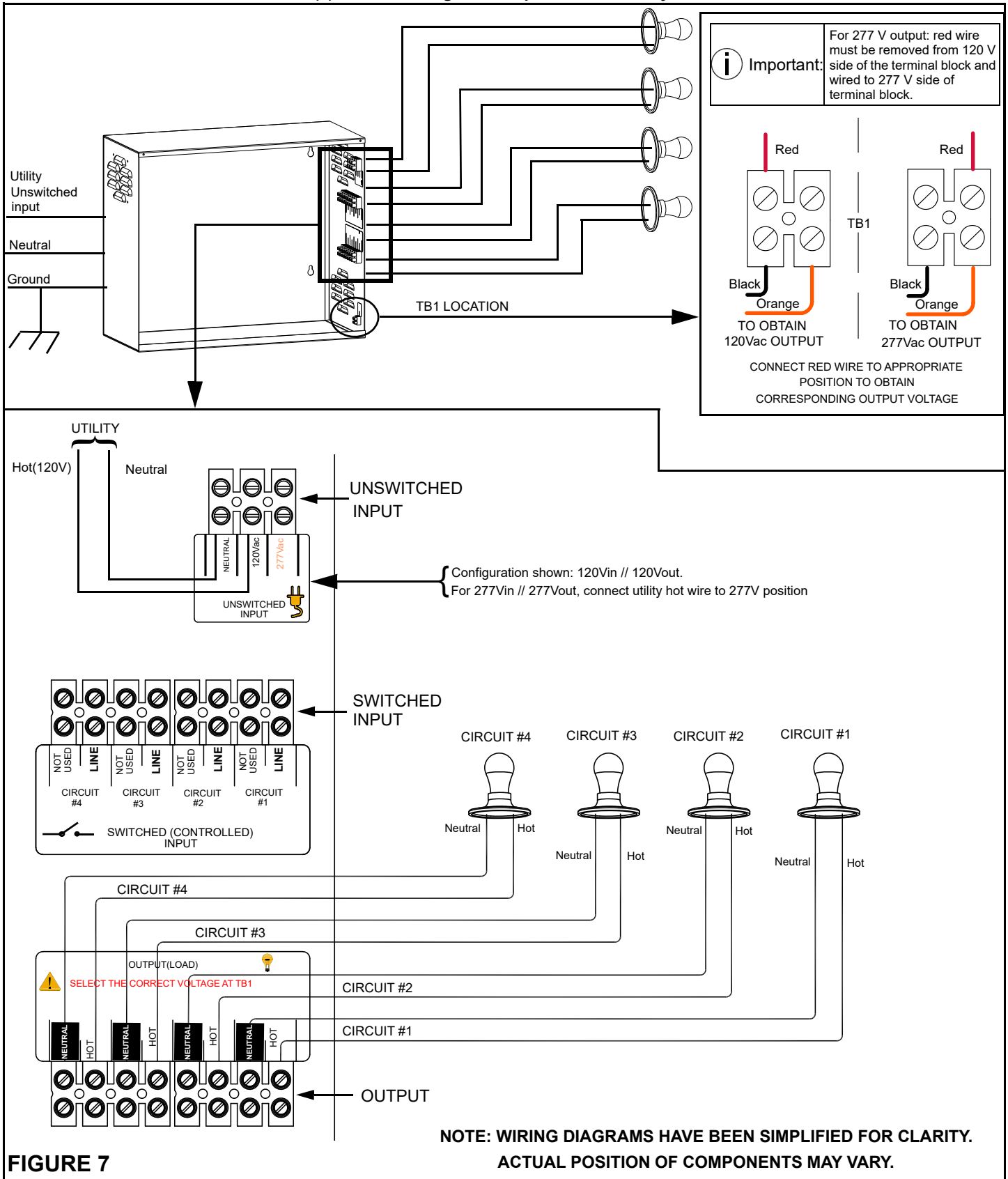

FIGURE 7

SWITCHED LOAD OPERATION

All four(4) circuits controlled by switches.

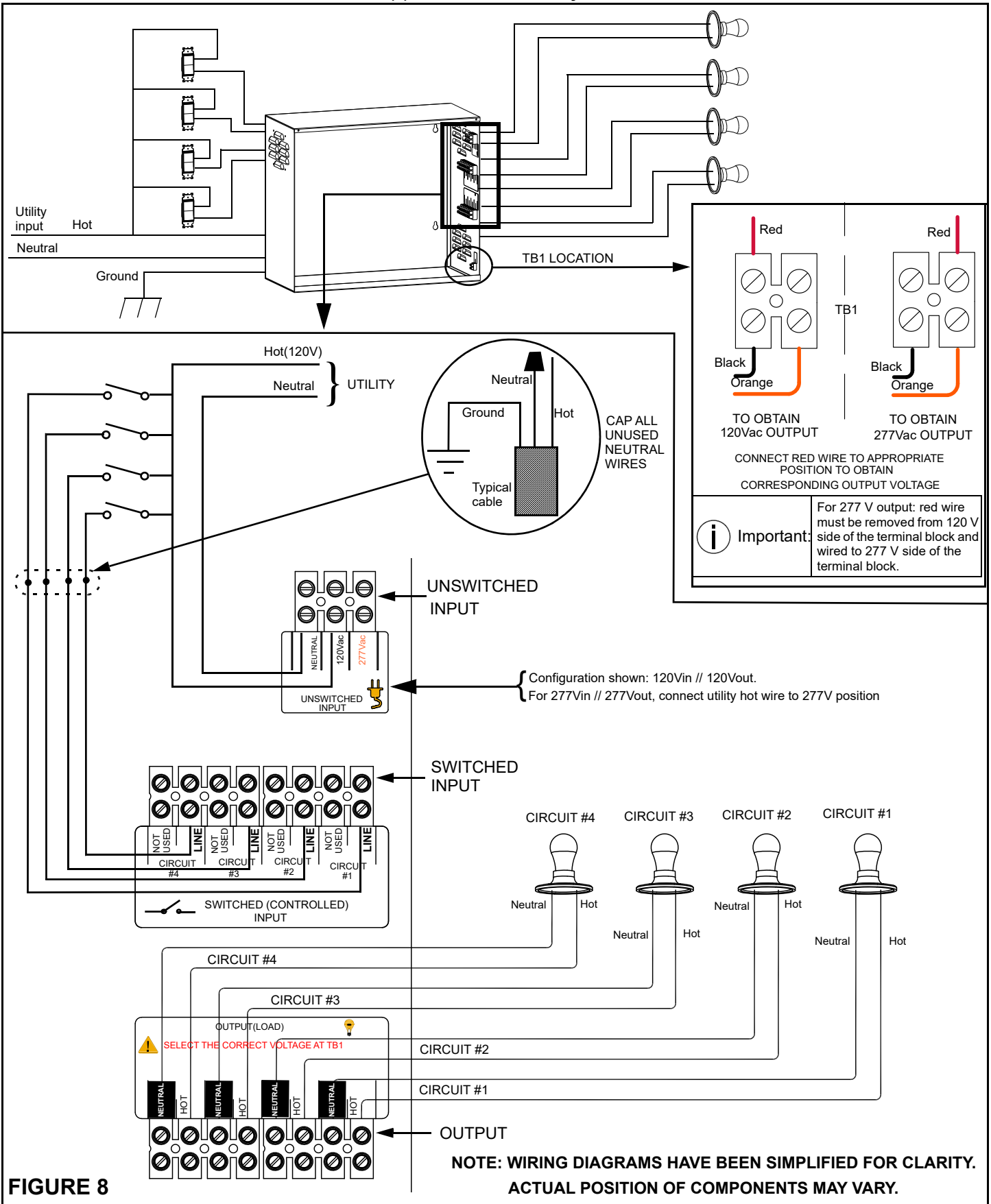

FIGURE 8

COMBINATION OF NORMALLY-ON, NORMALLY-OFF AND SWITCHED LOAD OPERATION

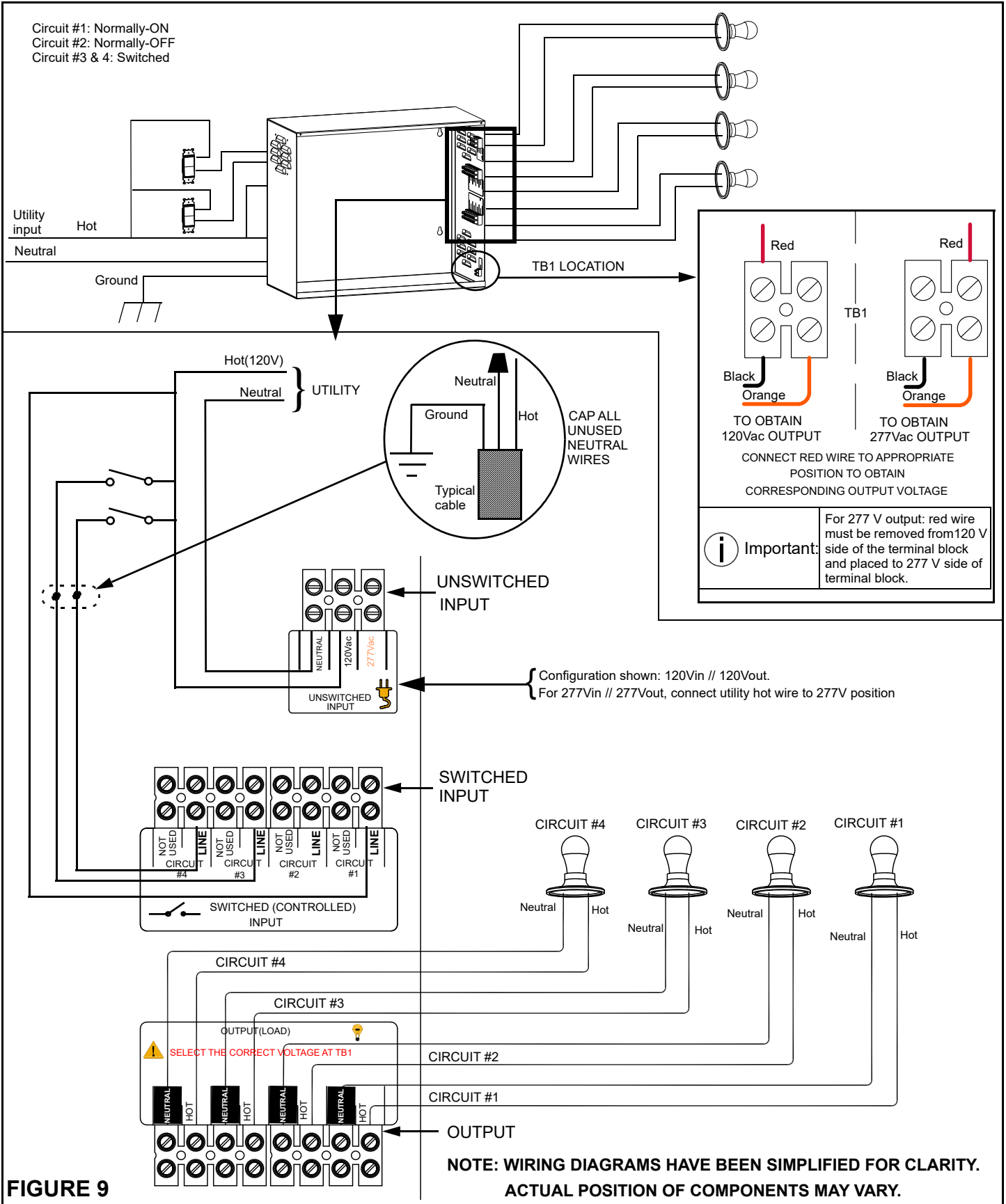

FIGURE 9

FEATURES AND OPTIONS

SYSTEM OPERATION

- The diagnostic/charger is a self-contained, fully automatic microcontroller-based system.
- When installation is complete, only the battery connection is needed. AC power need not be energized.
Unit goes directly into lockout mode and waits for AC power to be restored.

1. ALARM SILENCE / MANUAL TEST / SYSTEM INITIALIZATION

- Alarms are silenced by pushing the “TEST” switch less than one half second. Alarm can only be silenced after correcting the fault or by re-initializing the system.
- Press the “TEST” switch for 1 second to initiate a 1 minute manual test
- System initialization is done by holding “TEST” switch for at least 6 seconds.

2. DIAGNOSTIC AND NEXUS® (OPTION)

If audible alarm is activated, any fault condition will produce an audible warning of an intermittent beep: one second on, one second off.

See figure 10 for fault indicators.

a. BATTERY DISCONNECT / INVERTER FAILURE

Status indicator displays steady red LED if battery circuit is open or shorted, or if there is an inverter failure.

b. BATTERY FAILURE

1 red blink and a pause of 5 seconds: incorrect battery (e.g. 12V battery on a 6V system), or battery has failed a timed or forced test (reached LVD level before the end of the test).

c. CHARGER FAILURE

2 red blinks and a pause of 4 seconds: charging current is not within limits corresponding to charger command state.

d. LIGHTING LOAD CAPTURE SEQUENCE

Only initiated by a reset of system. Press “TEST” switch for at least 6 seconds. Reset initializes the main counter. This re-initialization takes place to compensate for system variations when the unit ages. Re-initialization is not allowed if there is a lighting load failure alarm. This is not applicable for units with “No-Auto-Test plus No-Load-Detect” option.

e. SERVER FAILURE

The Nexus server (controller or PC) is no longer communicating with the RF unit’s modem. Confirm Nexus server is operating and check whether other surrounding emergency lighting units are not powered. If surrounding emergency lighting units are powered “off”, the surrounding emergency lighting units will prevent communication with the modem. Otherwise, reset the modem.

f. BLINK MODE

A “Blink mode” signal was sent from the Nexus server (controller or PC) to the emergency lighting unit. To stop the “Blink mode”, access the Nexus server and execute a stop blink mode operation.

g. NOT COMMISSIONED

The unit is not registered in the Nexus server. Commission the unit. Auto-test will be disabled and the LED will show a steady green for 10 seconds and steady orange for 1 second.

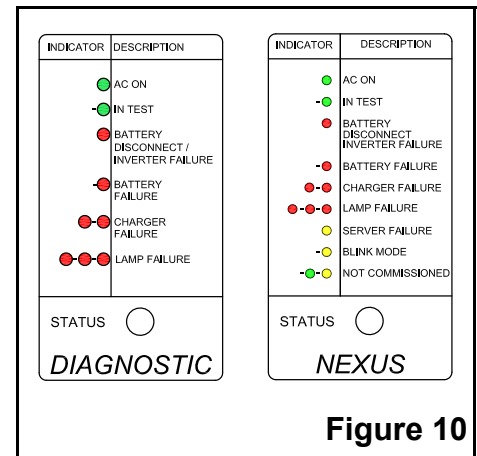

Figure 10

To cancel a fault alarm display, reset unit after issue correction.

*Refer to Nexus® installation addendum for more details.

⚠ IMPORTANT: Reset the system for each addition or change of lighting load. Press test switch for 6 seconds to reset the system.

3. AUTOMATIC UNIT TEST (30-DAY TEST)

Every 30 days, while in charging mode, the sequence generator will generate a command to energize the transfer on the emergency lighting circuit for a variable test period depending on the yearly sequence.

	US (MIN)
Monthly test	1
6 month test	30
12 month test	90

NOTE: AUTO-TESTING IS NOT PROVIDED IN SOME UNITS. REFER TO FEATURE 9.

- If the battery fails to complete the discharge test, the charger will display a battery failure and the test will abort.
- The 30-day automatic test sequence is reset every time the lighting load is turned on, including after a manual test.

4. LIGHTING LOAD TESTING

The test is fully automatic. To ensure accurate data from a connected and functional lighting load:

- The battery must be at or near full power. The program will delay data capture for a minimum of 48 hours following any discharge or reset.
- The charger must be in hysteresis mode (charger cycling on/off).



IMPORTANT: A minimum lamp load equivalent to 10% of the rated capacity of the unit must be installed.
Example: 40W for a 400W inverter unit.

5. AUDIBLE ALARM (BUZZER)

Can be activated or de-activated in the field. Refer to Figure 11.

To select the audible alarm option:

- Remove all power sources to the board (AC and battery).
- Use long-nose pliers to remove the shunt (little black box) from the pins.
- Replace the shunt back according to the option selection.
- Reconnect AC power and the battery.

6. SERVICE ALARM CONTACT (OPTION)

If installed, insert each wire of the Building Alarm Panel into separate terminals of the terminal block marked "SERVICE ALARM".

Alarm Panel will provide a 24V signal. The charger board will indicate a fault by closing a contact. Polarity is not specified.

7. LIGHTING CONTROL OVERRIDE

This feature is used with lighting loads equipped with low voltage dimming control. The dimming function will be disabled during a power failure in order for the load to provide a 100% light level.

The Mini Inverter comes with four Lighting Control Override circuits. In standby mode, the Lighting Control Signal cables from the lighting fixtures are connected through relay contacts to the Lighting Control Signal cables from the external Lighting Dimming Control panel. In emergency mode (power failure) the contacts of each relay open and the dimming signal from the lighting load is disconnected, allowing the load to operate at 100% light level.

INSTALLATION:

- The figure below illustrates the wiring of the Mini Inverter with 0-10V dimmable fixtures and external 0-10V Lighting Dimming Control device.

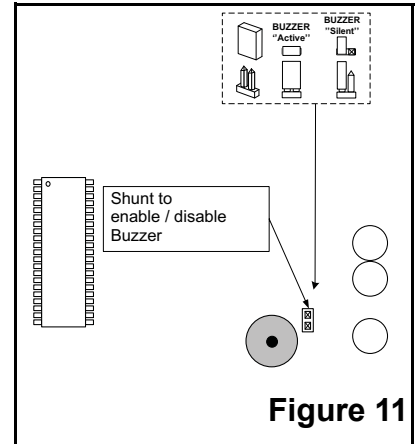

Figure 11

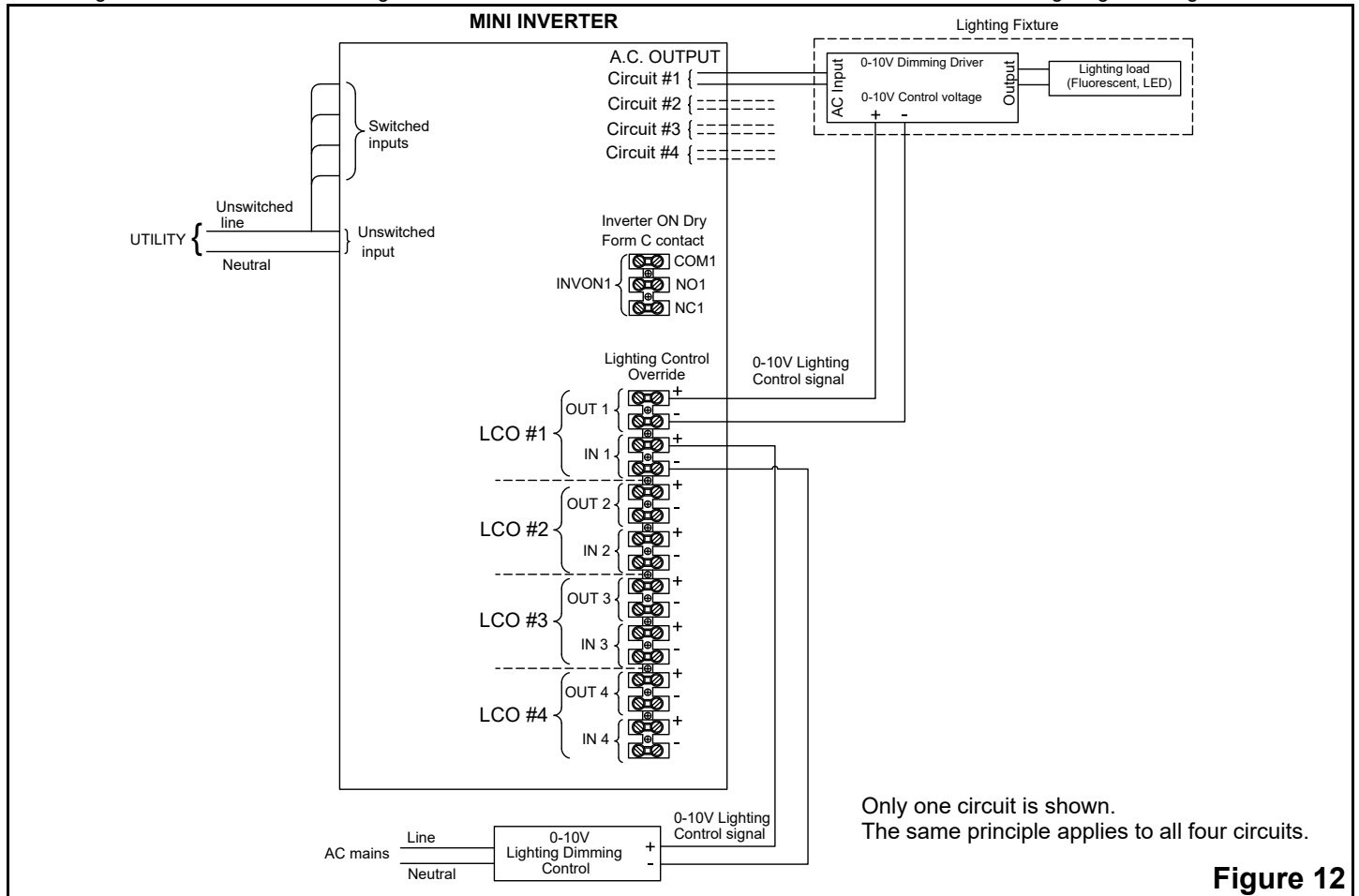

Figure 12

2. The terminal blocks for connecting the 0-10V dimming control wires are located on the left-hand side of the cabinet as illustrated in figure 13.

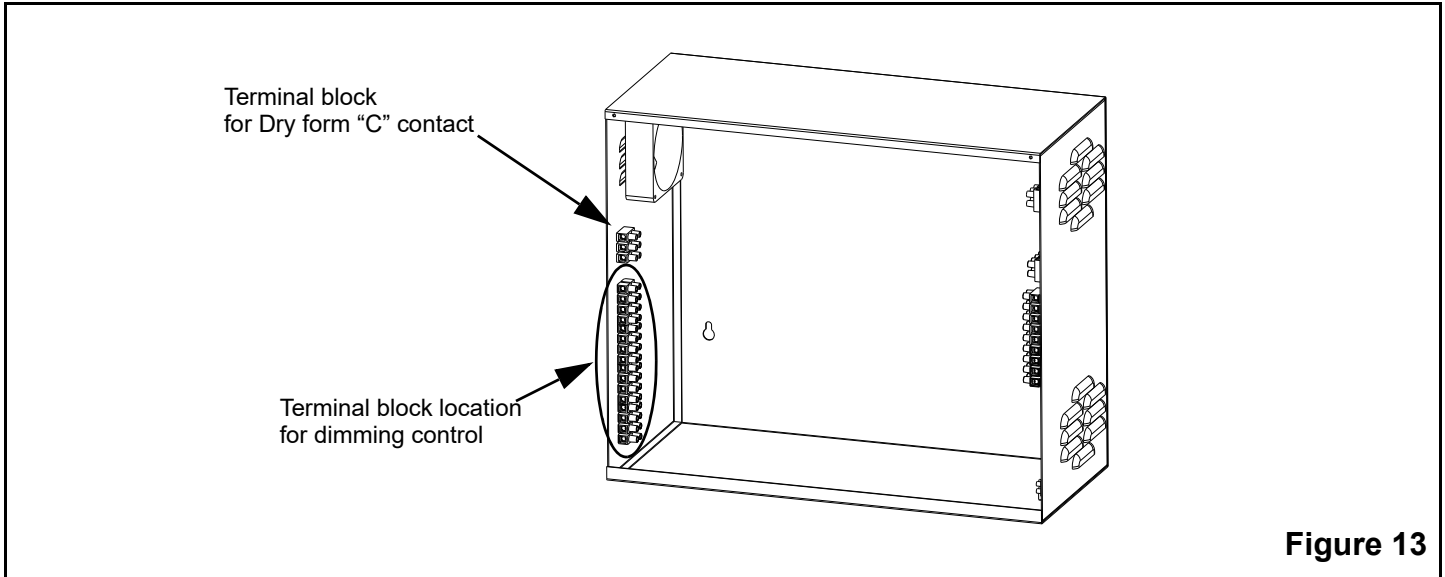

Figure 13

3. Connect the Lighting Control signal cables from the external Lighting Dimming Control panel to the terminal blocks identified by IN1, IN2, IN3 or IN4 in the Mini Inverter. Wiring is polarity sensitive. Observe the polarity of the cables to ensure proper installation. Purple is positive and grey is negative.
4. Connect the Lighting Control signal cables from the lighting fixtures to the corresponding terminal blocks identified by OUT1, OUT2, OUT3 or OUT4 in the Mini Inverter. Wiring is polarity sensitive. Observe the polarity of the cables (*refer to figure 12*). Purple is positive and grey is negative.

Note: Only one Lighting Control Override circuit has been shown for clarity. The same principle applies to all four Lighting Control Override circuits.

8. INVERTER-ON DRY CONTACT

The Mini-Inverter also comes with one set of INVERTER-ON Dry Form “C” contact.

The INVERTER-ON Dry Contact is identified as “INVON1” and its position is illustrated in **Figure 12 and 13**.

The INVERTER-ON Dry Form “C” contact changes position in emergency mode.

INVERTER-ON Dry Contact Specification:

Maximum voltage: 30 VDC

Maximum current: 2A

The Lighting Control Override board has one extra INVERTER-ON Dry Form “C” contact identified as “INVON2”. “INVON2” has the same specifications as “INVON1” and can be used if needed.

9. UNITS WITH NO AUTO-TEST (OPTION)

This equipment is not self-testing in conformance with the Life Safety Code, ANSI/NFPA 101.

TROUBLESHOOTING GUIDE

STATUS INDICATOR (LED)	TROUBLESHOOTING GUIDE		
	SYMPTOMS	PROBLEM	CORRECTIVE ACTION
 LED GREEN ON Steady, not flashing	Lamp load is on	None, if unit is in normally on mode.	Unit is operating correctly.
	Lamp load is off	None, if unit is in normally off mode.	Unit is operating correctly.
	Lamp load is OFF, but the unit is in normally on mode	Fuses burned out.	Verify there is no short circuit in the load. Replace fuses.
	-Lamp load is OFF (if installation is normally OFF) -Lamp load is ON (if installation is normally ON)	Power at primary AC input + battery discharged (at LVD) + no reaction with test button.	- Remove primary AC input + disconnect battery + wait minimum 10 seconds - connect battery + connect primary AC input => unit will restart - if unit did not restart, call technical support at 1-(888) 552-6467.
 LED flashing GREEN/ORANGE	Lamp load is ON	None if unit is in normally on mode +Nexus option.	Unit is operating correctly. Unit is not commissioned to the Nexus system.
	Lamp load is OFF	None if unit is in normally off mode +Nexus option.	Unit is operating correctly. Unit is not commissioned to the Nexus system.
 LED flashing GREEN/OFF	Lamp load is ON	None the unit is in test mode or is sampling load.	Unit is operating correctly.
	Lamp load is OFF	Inverter switched OFF.	Check the inverter ON/OFF switch => Turn it on. Switch is located on the right side of the inverter module.
		The output fuse is burnt	Replace the fuses after verifying that there is no short circuit in the load.
 LED steady OFF, not flashing	Lamp load is ON	No power at primary AC input + in emergency mode	Check position of breaker feeding the Mini Inverter in the breaker panel. If breaker has tripped, check for overload or short circuit. See "AC SPECS" on page 1.
	Lamp load is OFF	No power at primary AC input + emergency mode stop (battery discharged)	
	-Lamp load is OFF (if installation is normally OFF) -Lamp load is ON (if installation is normally ON)	Power at primary AC input + battery discharged (at LVD) + no reaction with test button	- Remove primary AC input + disconnect battery + wait minimum 10 seconds - connect battery + connect primary AC input => the unit will restart - if unit did not restart, call for technical support at 1-(888)-552-6467.

TROUBLESHOOTING GUIDE

 LED RED steady ON	Battery Disconnect Error	No battery installed in unit	Install battery following installation guide.
 LED Flashing RED 1 time every 6 seconds	Battery Failure	Battery fails to complete manual or monthly test.	Replace batteries.
		Battery fails to complete annual test.	Replace batteries.
		Battery fail in charge.	Replace batteries.
 LED Flashing RED 2 times every 6 seconds	Charger Failure	Charger not working.	Reset unit (see page 7). If same error is displayed, replace charger board.
 LED Flashing RED 3 times every 6 seconds	Lamp Failure	Loss of 10% or more of initial lamp load.	Replace the bad lamp and reset the unit.
	-Lamp Failure -No output voltage	Fuses are burned out.	Verify there is no short circuit in load. Replace fuses.
		Loose connection to terminal block	Verify that all wires are securely connected to terminal block.
 LED AMBER (ORANGE) steady On	Network server down	Nexus modem is not sending a signal to Nexus server.	See Nexus manual system.
 LED flashing between AMBER/OFF	Wink mode	Unit is in yellow blink mode.	Stop wink mode by sending a message from Nexus server or reset the unit (see page 12).

**CONTACT CUSTOMER SERVICE FOR REPLACEMENT PARTS.
 SERVICING MUST BE PERFORMED BY QUALIFIED PERSONNEL.
 Consult Customer Service for current warranty information.**

All information and specifications contained in these instructions are subject to change due to engineer design, errors and omissions.

© 2021 ABB. All rights reserved.