

EMERGI-LITE

Emerg-Power Systems

Central Emergency Lighting Inverter Systems



Series highlights

Performance

The Emerg-Power Systems works with any type of lighting load to provide full light output for minimum 90 min. It is designed to support incandescent, fluorescent, HID*, quartz re-strike or halogen lamps. It will work into these loads at cold starts for all normally off circuits or normally on circuits.

*except IPS systems

True Sine Waveform

Using a solid-state, pulse width modulation (PWM) inverter the systems produce pure sinusoidal output waveform with less than 3% maximum Total Harmonic Distortion (THD) for linear loads. Microprocessor and crystal controlled.

Reliability

The product is third generation inverter technology. Proven solid design with double ratings of all critical components. LVD (Low Voltage Disconnect) for long power outages eliminates battery drain.

Batteries

Front access connections for easy installation significantly reduce the footprint, installation and maintenance time while increasing safety. Automatic restart and recharge upon restoration of utility.

Approvals

UL listed to UL924. Meets UL924, NFPA101, NFPA70, NFPA 110, OSHA, UBC, SBCCI. N.Y. City approved.

Applications

Emerg-Power Systems can be used in almost every type of building, especially in architecturally sensitive applications or when maintenance costs and individual testing of unit equipment becomes very significant. Our systems are designed to work with power factor corrected as well as the most recent T5 and T5-HO electronic ballasts.

Options

A full range of options such as integrated output circuit breakers, bypass relays, dry contacts, etc., makes Emerg-Power Power Systems an industry leader in emergency lighting central systems (see page 12)

Features

Self-Diagnostic/Self-Testing

Programmable monthly and annual self-testing. Proven self-diagnostic with over 120 parameters stored in separate memory logs for Test, Event and Alarm. Microprocessor monitoring and control.

Low heat dissipation

Very low heat loss technology in normal operating mode (see specifications for exact values). Convection cooling in normal mode with forced air during emergency mode. Battery cabinets: convection cooling only.

Maximum Efficiency

Highest efficiency in the industry, 98% at 100% load with no requirement for cooling in normal operating mode. Low input harmonic distortion <10%.

Versatile Installation

Modular design, easy front access freestanding cabinets, fasten together when more than one cabinet is required. Optional seismic kit available. All wiring provided is pre-cut and terminated, along with the necessary hardware and electrical fittings, for proper installation.

Complete Protection

Input circuit breaker and fused battery circuit is standard. Systems offer overload capacity, short-circuit protection, current-limiting, low-battery disconnect, reverse polarity and brownout protection as standard.

Thermal Performance

Bonded fin heat sink technology for maximum thermal performance. Cooling fans are energized only in inverter mode.

Monitoring and Control

User friendly programmable interface with LED indicators and LCD display provides full metering values, easy program and control functions and a wide range of visual and audible alarms.

System type

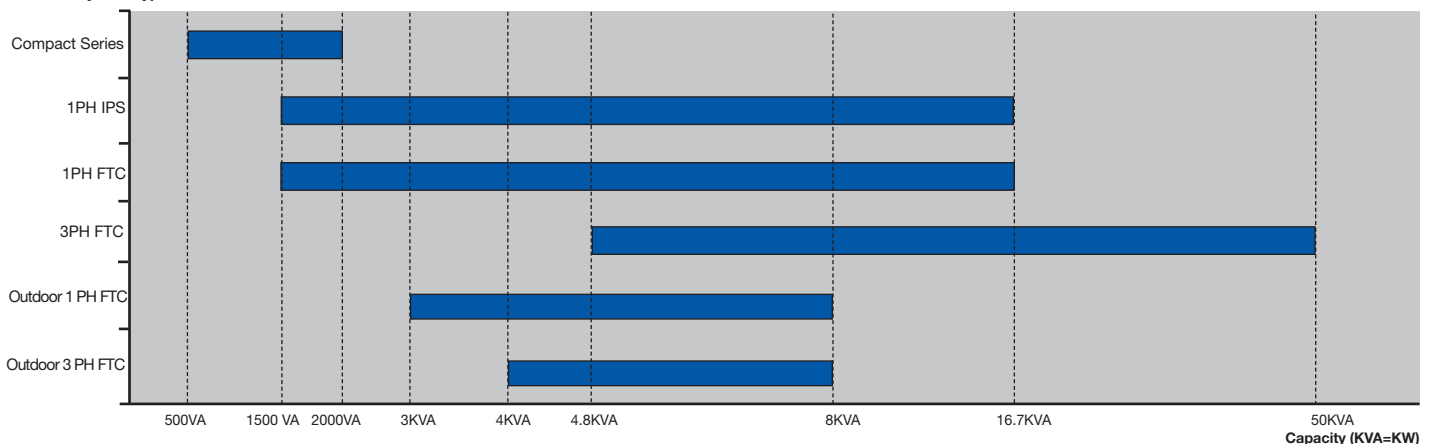

Benefits

Compliance with NFPA101

The self-testing meets the requirements of NFPA and UL. User programmable time of testing. Test results, events or alarms can be downloaded from history logs. Load monitoring. Reduced testing/service time.

Less air-conditioning

Reduced costs for air-conditioning required to ensure the optimum operating temperature when compared with equivalent systems that dissipate much more heat. Higher reliability of fans and the electronic components.

Lower energy bills

Low consumption of the system itself will result in lower energy bills paid over the system life time. Comparative analysis available on request.

Easy to install

Quick installation and connection through flexible cable entries and fast access terminal blocks. Reduced footprint for systems with stackable cabinets. Low MTTR (<15 min.) due to modular design, quick disconnect means and frontal access.

Reduced damage risks

The full protection of the system will eliminate damage created by external events and will increase lifetime of the electronics and the batteries. Also will provide safety during maintenance.

Increased MTBF

Increased reliability and reduced preventative maintenance. No air filters needed.

Easy maintenance

Easier diagnostic, troubleshooting, preventative maintenance and service through the indicators and display or by using the history logs. Remote versions available.

SUMMARY

■ GENERAL PRESENTATION	PAGE 1,2
■ SINGLE PHASE COMPACT SYSTEMS	PAGE 3,4
■ SINGLE PHASE INTERRUPTIBLE SYSTEMS	PAGE 5,6
■ SINGLE PHASE FAST TRANSFER SYSTEMS	PAGE 7,8
■ THREE PHASE FAST TRANSFER SYSTEMS	PAGE 9,10
■ OUTDOOR SYSTEMS	PAGE 11
■ OPTIONAL FEATURES - DETAILS	PAGE 12
■ USER INTERFACE AND DISPLAY	PAGE 13
■ WHAT TO CONSIDER WHEN REQUESTING A CENTRAL SYSTEM	PAGE14

Emerg-Power Systems COMPACT SERIES

Uninterruptible emergency lighting, 1PH,
inverter system 500VA – 2000VA



For all fluorescent/incandescent or HID light loads

Features:

- 98% efficient @ full load
- PWM/MOSFET technology
- Self-testing/Self-diagnostic
- User programmable with password protection
- Standard input circuit breaker
- Standard output circuit breaker
- Micro-processor controlled
- Floor or wall mountable
- Field upgradeable (500VA steps)
- 90 min. standard run time
- Electronic and magnetic ballast compatible
- Automatic event, test and alarm log
- LCD display
- Very small footprint (stackable cabinets)
- Maintenance free standard batteries
- Forced air cooling during emergency mode only

UL listed to UL924. Meets NFPA101, NFPA70, NFPA 110,
OSHA, UBC, SBCCI. N.Y City approved.

ELECTRICAL/MECHANICAL CHARACTERISTICS ⁽⁴⁾

Power Rating ⁽¹⁾ VA=W	Effic. at full load %	Max. input current (A)		Heat loss in normal mode (BTU/hr)	Batt. VDC	Batt. A	No. of batt.	UPS cabinet dimensions			Battery cabinet dimensions ⁽²⁾⁽³⁾			No. of batt cab.	Batt. cab. weight lbs (empty)	UPS cab. weight lbs	Batt. weight lbs	Total system weight (lbs)
		120 V	277 V					W"	H"	D"	W"	H"	D"					
500	98	5.2	2.3	34	48	13.5	4	26	10	10	26	10	10	1	22	77	107	206
1000	98	10.5	4.5	68	48	26.5	8	26	10	10	26	10	10	2	22	77	214	335
1500	98	15.6	6.8	102	48	40	12	26	10	10	26	10	10	3	22	77	321	464
2000	98	20.8	9	136	48	52	16	26	10	10	26	10	10	4	22	77	428	592

- 1- system capacity can be upgraded in the field up to 2000VA by adding more battery cabinets. Re-programming required by factory service technician.
 2- batteries are installed in separate modular cabinets
 3- battery cabinets are stackable. Must be installed under the electronics cabinet
 4- special voltages can change the size, weight or number of cabinets

ORDERING INFORMATION

Example: 120SG1500-FTCM-120-90-ICB-OCB0420-WB

Input voltage ⁽³⁾	Battery type	VA/W rating	System type	Output voltage ⁽³⁾	Run time ⁽²⁾	Input breaker	Output breakers ⁽⁴⁾	Options ⁽¹⁾
120 277	SG- lead calcium	500 1000 1500 2000	FTCM	120 277	90	ICB	OCBxxxx* OCAxxxx*	NOFF- normally OFF output WB- wall mount bracket DCS- dry summary alarm contacts INVON- inverter on dry contact VTD- variable time delay BPR- bypass relay RMP- remote metering panel RSAP- remote summary alarm panel RS232- communication interface MOD- modem

- 1- see page 12 for options description
 2- other run times available
 3- special voltages may change the size, weight or number of cabinets
 4- max. 2 more additional output breakers for a total of 3. See page 12 for output breakers details.

SYSTEM SPECIFICATIONS

GENERAL

Design	Stand-by no break. PWM inverter type utilizing MOSFET technology with 2ms transfer time.
Control	Microprocessor controlled , 2 x 20-character display with touch pad controls & functions 5 LED indicators & alarm with ring-back feature
Metering	Input & Output Voltage, Battery Voltage, Battery & Output Current, Output VA, Temperature, Inverter Wattage
Communications	Optional RS-232 port (DB9)

ELECTRICAL INPUT

Voltage	120 or 277VAC 1-phase 2-wire +10% - 15%. Contact factory for all other voltages.
Input Power Walk-In	Limiting inrush current to less than 125%, 10 times for 1 line cycle
Input Frequency	60Hz, +/-3Hz
Protection	Standard Input Circuit Breaker
Harmonic Distortion	<10%
Power Factor	0.5 lag/lead

ELECTRICAL OUTPUT

Voltage	120 or 277VAC 1-phase 2-wire. Contact factory for all other voltages.
Static Voltage	Load current change +/-2%, battery discharge +/-12.5%
Dynamic Voltage	+/-2% for +/-25% load step change, +/-3% for a 50% load step change, recovery within 3 cycles
Harmonic Distortion	<3% THD for linear load
Output Frequency	60Hz +/- 0.05Hz during emergency mode
Load Power Factor	0.5 lag to 0.5 lead
Inverter Overload	115% for 5 minutes
Protection	Standard Output Circuit Breaker (normally on)
Crest Factor	2.8

ENVIRONMENTAL CONDITIONS

Storage/Transport	-4°F to 158°F (-20°C to 70°C) without batteries -0°F to 104°F (-18°C to 40°C) with batteries ⁽¹⁾
Operating temperature	System operates safely from 32°F to 104°F (0°C to 40°C) but optimum operation is between 68° F and 86°F (20°C to 30°C). Battery performance can be affected by temperature.
Altitude	<10,000 feet (above sea level) without de-rating
Relative Humidity	0 to 95% non-condensing
Audible noise	45 dBA @ 1m from surface in emergency mode

1- max. 3 months at 104° F (40° C)

SINGLE LINE DIAGRAM

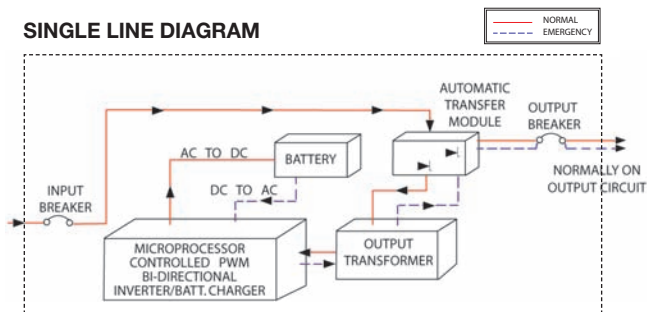

CABINETS

Modular design, freestanding or wall mount NEMA type 1 steel cabinets powder coated for corrosion and scratch resistance. Front access design. Cabinets are stackable. Top and left side conduit entry with knockouts.

INVERTER

Using MOSFET/PWM technology the inverter converts the DC voltage supplied by the batteries to AC voltage of a precise stabilized amplitude and frequency, suitable for most sophisticated electrical equipment. True sinusoidal output waveform with very low distortion (less than 3% for linear loads). Overload capability of up to 150% for 12 line cycles.

CHARGER

Fully automatic, temperature compensated, microprocessor controlled charger recharges fully discharged batteries in maximum 24 hours at nominal AC input voltage. AC input current limiting and over-voltage protection included.

BATTERY

System is provided with 10 year, maintenance free, sealed valve regulated lead calcium batteries. 90 min. standard discharge time at full load under normal operating temperature. Low Voltage Disconnect protection included. No special ventilation required.

SUPERVISION

Automatic self-test consists of a 5-minute monthly and 90-minute annual function. The front-mounted control panel includes 5 LED indicators, a 2-line 20-character LCD display, a keypad to control and monitor the internal operation of the system. This allows the operator to easily "watch" system functions as they occur and check on virtually any aspect of the system's operation. Self-diagnostic function monitors, controls, generates alarms and memorizes events.

ALARMS

High/Low Battery Charger Voltage, High/Low AC Input Voltage, Near Low Battery, Low Battery, Load Reduction Fault, Output Overload, High Ambient Temperature, Inverter Fault, Output Fault, Optional Output Circuit Breaker Trip

OPTIONAL FEATURES

Normally OFF output, Output Circuit Breakers, Output Trip Alarm, RS232 communication port, 12 Hours Fast Recharge, Remote Meter Panel, Remote Summary Alarm Panel, Summary Alarm Dry Form C Contact, Inverter on Dry Contacts, Variable Time Delay, Modem, Bypass Relays, Wall mount bracket

FACTORY START-UP

Includes one additional year of warranty. See warranty conditions.

WARRANTY

(full limited warranty conditions available upon request)
Limited manufacturer warranty is one-year, parts and labor, for system electronics or two-year with factory start-up program. Battery warranty is one year full plus 9 years pro-rata for a total of 10 years, under normal operating conditions. System must be put in service within 180 days from ship date in order to validate warranty.

Emerg-Power Systems IPS SINGLE PHASE SERIES

Interruptible emergency lighting
inverter system 1.5KVA –16.7KVA



For all fluorescent/incandescent loads

Features:

- 98% efficient @ full load
- PWM/IGBT technology
- Self-testing/Self-diagnostic
- User programmable with password protection
- Standard input circuit breaker
- Standard Normally Off output
- RS232 communication port
- Micro-processor controlled
- Automatic event and alarm log
- 90 min. standard run time
- Generator compatibility
- Electronic and magnetic ballast compatible
- Custom voltages available
- Automatic event, test and alarm log
- LCD display
- Reduced footprint (stackable cabinets)
- Maintenance free standard batteries
- Forced air cooling during emergency mode only

UL listed to UL924. Meets NFPA101, NFPA70,
NFPA 110, OSHA, UBC, SBCCI. N.Y City approved.

ELECTRICAL/MECHANICAL CHARACTERISTICS⁽⁴⁾ (data provided for standard lead calcium batteries)⁽¹⁾⁽⁴⁾

Power rating kVA/kW	Effic. at full load %	Max. input current (A)		Heat loss in normal mode (BTU/hr)	Batt. VDC	Batt. A	No. of batt.	UPS cabinet dimensions			Battery cabinet dimensions ^{(2) (3)}			No. of batt cab.	Batt. cab. weight lbs (empty)	UPS cab. weight lbs	Batt. weight lbs	Total system weight lbs
		120 V	277 V					W"	H"	D"	W"	H"	D"					
1.5	98	16	7	102	48	39	4	30	47	25	NA	NA	NA	NA	NA	250	296	546
2.25	98	24	11	153	72	38	6	30	47	25	NA	NA	NA	NA	NA	265	444	709
3	98	32	14	204	96	38	8	30	47	25	NA	NA	NA	NA	NA	295	592	887
3.75	98	39	17	255	120	37	10	30	47	25	NA	NA	NA	NA	NA	305	740	1045
5	98	50	22	340	144	40	12	30	47	25	NA	NA	NA	NA	NA	315	888	1203
6	98	63	27	408	180	40	15	30	47	25	30	47	25	1	210	350	1110	1670
8	98	84	36	544	240	39	20	30	47	25	30	47	25	1	232	375	1480	2087
10	98	105	45	680	144	82	24	30	47	25	30	47	25	2	420	435	1776	2631
12.5	98	131	57	850	180	82	30	30	47	25	30	47	25	2	420	465	2220	3105
16.7	98	174	76	1136	240	80	40	30	47	25	30	47	25	2	464	530	2960	3954

1-consult factory for 20 year type batteries or for wet nickel cadmium batteries

2- batteries are installed in the electronics cabinet for 1.5 to 5kVA systems

3- battery cabinets are stackable. To be installed on the right side of the electronics cabinet

4- special voltages or batteries may change the size, weight or number of cabinets

ORDERING INFORMATION

Example: 277SG6000-IPS-277-90-ICB-RS232-OCB0420-DCS-20Y

Input voltage ⁽³⁾	Battery type	VA/W rating	System type	Output voltage ⁽³⁾	Run time ⁽²⁾	Input breaker	RS232 port	Output breakers ⁽⁴⁾	Options ⁽¹⁾
120	SG - sealed lead calcium	1500	IPS	120	90	ICB	RS232	OCBxxxx - no trip alarm	20Y - 20 yr sealed batteries 12HR - 12 hr fast recharge MBYP - internal bypass switch EMBP - external bypass switch ⁽⁵⁾ RMP - remote metering panel RSAP - remote summary alarm panel DCS - dry summary alarm contacts INVON - inverter on dry contacts VTD - variable time delay MOD - external modem FAX - fax modem BPR - bypass relays DIAL - autodialer SEIS - seismic mounting ZONEM - zone monitoring BATM - battery cycle warranty monitor
208		2250		277					
240	NC - wet nickel cadmium	3000		208					
277		3750		120/240					
		5000		120/277					
		6000						OCAxxxx - with trip alarm	
		8000							
		10000							
		12500							
		16700							

1- see page 12 for options description

2- other run times available

3- special voltages may change the size, weight or number of cabinets

4- max. 12 unsupervised single pole positions or 8 with trip alarm. For more output breakers please consult factory. See page 12 for output breakers option details.

5- external bypass switch is not compatible with integrated output circuit breakers. Input/output voltage has to be the same.

SYSTEM SPECIFICATIONS

GENERAL

Design	Stand-by no break. PWM inverter type utilizing IGBT technology with 50ms transfer time.
Control	Microprocessor controlled , 2 x 20-character display with touch pad controls & functions 5 LED indicators & alarm with ring-back feature
Metering	Input & Output Voltage, Battery Voltage, Battery & Output Current, Output VA, Temperature, Inverter Wattage
Communications	RS-232 port (DB9)

ELECTRICAL INPUT

Voltage	120 or 277VAC 1-phase 2-wire +10% - 15%. Contact factory for all other voltages.
Input Power Walk-In	Limiting inrush current to less than 125%, 10 times for 1 line cycle
Input Frequency	60Hz, +/-3%, 50Hz available upon request
Protection	Input Circuit Breaker
Harmonic Distortion	<10%
Power Factor	0.5 lag/lead

ELECTRICAL OUTPUT

Voltage	120 or 277VAC 1-phase 2-wire. Contact factory for all other voltages.
Static Voltage	Load current change +/-2%, battery discharge +/-12.5%
Dynamic Voltage	+/-2% for +/-25% load step change, +/-3% for a 50% load step change, recovery within 3 cycles
Harmonic Distortion	<3% THD for linear load
Output Frequency	60Hz +/- 0.05Hz during emergency mode
Load Power Factor	0.5 lag to 0.5 lead
Inverter Overload	125% for 5 minutes
Protection	Optional Distribution Circuit Breaker
Crest Factor	2.8

ENVIRONMENTAL CONDITIONS

Storage/Transport	-4°F to 158°F (-20°C to 70°C) without batteries -0°F to 104°F (-18°C to 40°C) with batteries ⁽¹⁾
Operating temperature	System operates safely from 32°F to 104°F (0°C to 40°C) but optimum operation is between 68° F and 86°F (20°C to 30°C). Battery performance can be affected by temperature.
Altitude	<10,000 feet (above sea level) without de-rating
Relative Humidity	0 to 95% non-condensing
Audible noise	45 dBA @ 1m from surface in emergency mode

1- max. 3 months at 104° F (40° C)

SINGLE LINE DIAGRAM

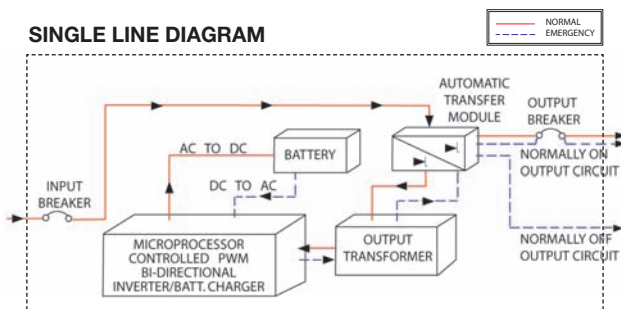

*output breakers are optional

CABINETS

Modular design, freestanding NEMA type 1 steel cabinets powder coated for corrosion and scratch resistance. Front access design through hinged lockable doors requires only 39" front clearance and 12" top clearance. Cabinets are stackable if required to further reduce the footprint. Top and left side conduit entry with knockouts.

INVERTER

Using IGBT/PWM technology the inverter converts DC voltage supplied by the batteries to AC voltage of a precise stabilized amplitude and frequency, suitable for most sophisticated electrical equipment. True sinusoidal output waveform with very low distortion (less than 3% for linear loads). Overload capability of up to 150% for 12 line cycles.

CHARGER

Fully automatic, temperature compensated, microprocessor controlled charger recharges fully discharged batteries in maximum 24 hours at nominal AC input voltage. AC input current limiting and over-voltage protection included.

BATTERY

System is provided standard with 10 year, maintenance free, sealed valve regulated, front terminals lead calcium batteries. 20 years life sealed lead calcium or wet nickel cadmium batteries also available. 90 min. standard discharge time at full load under normal operating temperature. Low Voltage Disconnect protection included. No special ventilation required.

SUPERVISION

Automatic self tests consist of a 5-minute monthly and 90-minute annual function. The front-mounted control panel includes 5 LED indicators, a 2-line 20-character LCD display, a keypad to control and monitor the internal operation of the system. This allows the operator to easily "watch" system functions as they occur and check on virtually any aspect of the system's operation. Standard RS232 diagnostic interface.

ALARMS

High/Low Battery Charger Voltage, High/Low AC Input Voltage, Near Low Battery, Low Battery, Load Reduction Fault, Output Overload, High Ambient Temperature, Inverter Fault, Output Fault, Optional Output Circuit Breaker Trip

OPTIONAL FEATURES

Output Circuit Breakers, Output Trip Alarms, 20 Years Sealed Batteries, 12 Hours Fast Recharge, Internal/External Maintenance Bypass Switch, Remote Meter Panel, Remote Summary Alarm Panel, Summary Alarm Dry Form C Contact, Inverter on Dry Contacts, Fax/Modem, Bypass Relays, Auto Dialer, Seismic Mounting.

FACTORY START-UP

Includes one additional year of warranty. See warranty conditions.

WARRANTY

(full limited warranty conditions available upon request)

Limited manufacturer warranty is one-year, parts and labor, for system electronics or two-year with factory start-up program. Battery warranty is one year full plus 9 years pro-rata for a total of 10 years, under normal operating conditions. ⁽²⁾ System must be put in service within 6 months from ship date in order to validate warranty.

2- Consult factory for other type batteries than the standard one.

Emerg-Power Systems FTC SINGLE PHASE SERIES

Uninterruptible emergency lighting
inverter system 1.5KVA –16.7KVA



Features:

- 98% efficient @ full load
- PWM/IGBT technology
- Self-testing/Self-diagnostic
- User programmable with password protection
- Standard input circuit breaker
- RS232 communication port
- Micro-processor controlled
- Automatic event and alarm log
- 90 min. standard run time
- Generator compatibility
- Electronic and magnetic ballast compatible
- Custom voltages available
- Automatic event, test and alarm log
- LCD display
- Reduced footprint (stackable cabinets)
- Maintenance free standard batteries
- Forced air cooling during emergency mode only

For all fluorescent/incandescent or HID light loads

UL listed to UL924. Meets NFPA101, NFPA70, NFPA 110, OSHA, UBC, SBCCI. N.Y City approved.

ELECTRICAL/MECHANICAL CHARACTERISTICS⁽⁴⁾ (data provided for standard lead calcium batteries)^{(1) (4)}

Power rating kVA/kW	Effic. at full load %	Max. input current (A)		Heat loss in normal mode (BTU/hr)	Batt. VDC	Batt. A	No. of batt.	UPS cabinet dimensions			Battery cabinet dimensions ^{(2) (3)}			No. of batt. cab.	Batt. cab. weight lbs (empty)	UPS cab. weight lbs	Batt. weight lbs	Total system weight lbs
		120 V	277 V					W"	H"	D"	W"	H"	D"					
1.5	98	16	7	102	48	39	4	30	47	25	NA	NA	NA	NA	NA	250	296	546
2.25	98	24	11	153	72	38	6	30	47	25	NA	NA	NA	NA	NA	265	444	709
3	98	32	14	204	96	38	8	30	47	25	NA	NA	NA	NA	NA	295	592	887
3.75	98	39	17	255	120	37	10	30	47	25	NA	NA	NA	NA	NA	305	740	1045
5	98	50	22	340	144	40	12	30	47	25	NA	NA	NA	NA	NA	315	888	1203
6	98	63	27	408	180	40	15	30	47	25	30	47	25	1	210	350	1110	1670
8	98	84	36	544	240	39	20	30	47	25	30	47	25	1	232	375	1480	2087
10	98	105	45	680	144	82	24	30	47	25	30	47	25	2	420	435	1776	2631
12.5	98	131	57	850	180	82	30	30	47	25	30	47	25	2	420	465	2220	3105
16.7	98	174	76	1136	240	80	40	30	47	25	30	47	25	2	464	530	2960	3954

1-consult factory for 20 year type batteries or for wet nickel cadmium batteries

2- batteries are installed in the electronics cabinet for 1.5 to 5kVA systems

3- battery cabinets are stackable. To be installed on the right side of the electronics cabinet

4- special voltages or batteries may change the size, weight or number of cabinets

ORDERING INFORMATION

Example: 277SG6000-FTC-277-90-ICB-RS232-OCB0420-DCS-20Y

Input voltage ⁽³⁾	Battery type	VA/W rating	System type	Output voltage ⁽³⁾	Run time ⁽²⁾	Input breaker	RS232 port	Output breakers ⁽⁴⁾	Options ⁽¹⁾
120	SG - sealed lead calcium	1500	FTC	120	90	ICB	RS232	OCBxxxx - no trip alarm	20Y - 20 yr sealed batteries 12HR - 12 hr fast recharge MBYP - internal bypass switch EMBP - external bypass switch ⁽⁵⁾ RMP - remote metering panel RSAP - remote summary alarm panel DCS - dry summary alarm contacts INVON - inverter on dry contacts NOFF - normally OFF output ⁽⁶⁾ MOD - external modem FAX - fax modem BPR - bypass relays DIAL - autodialer SEIS - seismic mounting ZONEM - zone monitoring BATM - battery cycle warranty monitor
208		2250		277					
240	NC - wet nickel cadmium	3000		208					
277		3750		120/240					
		5000		120/277					
		6000							
		8000							
		10000							
		12500							
		16700							

1- see page 12 for options description

2- other run times available

3- special voltages may change the size, weight or number of cabinets

4- max. 12 unsupervised single pole positions or 8 with trip alarm. For more output breakers please consult factory. See page 12 for output breakers option details.

5- external bypass switch is not compatible with integrated output circuit breakers. Input/output voltage has to be the same

6- normally off loads cannot exceed 20% of total KVA rating with any combination of H.I.D. loads.

SYSTEM SPECIFICATIONS

GENERAL

Design	Stand-by no break. PWM inverter type utilizing IGBT technology with 2ms transfer time.
Control	Microprocessor controlled, 2 x 20-character display with touch pad controls & functions 5 LED indicators & alarm with ring-back feature
Metering	Input & Output Voltage, Battery Voltage, Battery & Output Current, Output VA, Temperature, Inverter Wattage
Communications	RS-232 port (DB9)

ELECTRICAL INPUT

Voltage	120 or 277VAC 1-phase 2-wire +10% - 15%. Contact factory for all other voltages.
Input Power Walk-In	Limiting inrush current to less than 125%, 10 times for 1 line cycle
Input Frequency	60Hz, +/-3%, 50Hz available upon request
Protection	Input Circuit Breaker
Harmonic Distortion	<10%
Power Factor	0.5 lag/lead

ELECTRICAL OUTPUT

Voltage	120 or 277VAC 1-phase 2-wire. Contact factory for all other voltages.
Static Voltage	Load current change +/-2%, battery discharge +/-12.5%
Dynamic Voltage	+/-2% for +/-25% load step change, +/-3% for a 50% load step change, recovery within 3 cycles
Harmonic Distortion	<3% THD for linear load
Output Frequency	60Hz +/- 0.05Hz during emergency mode
Load Power Factor	0.5 lag to 0.5 lead
Inverter Overload	125% for 5 minutes
Protection	Optional Distribution Circuit Breaker
Crest Factor	2.8

ENVIRONMENTAL CONDITIONS

Storage/Transport	-4°F to 158°F (-20°C to 70°C) without batteries -0°F to 104°F (-18°C to 40°C) with batteries ⁽¹⁾
Operating temperature	System operates safely from 32°F to 104°F (0°C to 40°C) but optimum operation is between 68°F and 86°F (20°C to 30°C). Battery performance can be affected by temperature.
Altitude	<10,000 feet (above sea level) without de-rating
Relative Humidity	0 to 95% non-condensing
Audible noise	45 dBA @ 1m from surface in emergency mode

1- max. 3 months at 104° F (40° C)

SINGLE LINE DIAGRAM

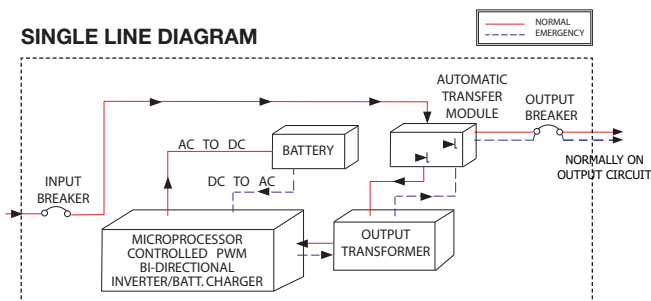

*output breakers are optional

CABINETS

Modular design, freestanding NEMA type 1 steel cabinets powder coated for corrosion and scratch resistance. Front access design through hinged lockable doors requires only 39" front clearance and 12" top clearance. Cabinets are stackable if required to further reduce the footprint. Top and left side conduit entry with knockouts.

INVERTER

Using IGBT/PWM technology the inverter converts the DC voltage supplied by the batteries to AC voltage of a precise stabilized amplitude and frequency, suitable for most sophisticated electrical equipment. True sinusoidal output waveform with very low distortion (less than 3% for linear loads). Overload capability of up to 150% for 12 line cycles.

CHARGER

Fully automatic, temperature compensated, microprocessor controlled charger recharges fully discharged batteries in maximum 24 hours at nominal AC input voltage. AC input current limiting and over-voltage protection included.

BATTERY

System is provided standard with 10 year, maintenance free, sealed valve regulated, front terminals lead calcium batteries. 20 years life sealed lead calcium or wet nickel cadmium batteries also available. 90 min. standard discharge time at full load under normal operating temperature. Low Voltage Disconnect protection included. No special ventilation required.

SUPERVISION

Automatic self tests consist of a 5-minute monthly and 90-minute annual function.

The front-mounted control panel includes 5 LED indicators, a 2-line 20-character LCD display, a keypad to control and monitor the internal operation of the system. This allows the operator to easily "watch" system functions as they occur and check on virtually any aspect of the system's operation. Standard RS232 diagnostic interface.

ALARMS

High/Low Battery Charger Voltage, High/Low AC Input Voltage, Near Low Battery, Low Battery, Load Reduction Fault, Output Overload, High Ambient Temperature, Inverter Fault, Output Fault, Optional Output Circuit Breaker Trip

OPTIONAL FEATURES

Output Circuit Breakers, Output Trip Alarms, 20 Years Sealed Batteries, 12 Hours Fast Recharge, Internal/External Maintenance Bypass Switch, Remote Meter Panel, Remote Summary Alarm Panel, Summary Alarm Dry Form C Contact, Inverter on Dry Contacts, Normally OFF output, Fax/Modem, Bypass Relays, Auto Dialer, Seismic Mounting.

FACTORY START-UP

Includes one additional year of warranty. See warranty conditions.

WARRANTY

(full limited warranty conditions available upon request)

Limited manufacturer warranty is one-year, parts and labor, for system electronics or two-year with factory start-up program. Battery warranty is one year full plus 9 years pro-rata for a total of 10 years, under normal operating conditions.⁽²⁾ System must be put in service within 6 months from ship date in order to validate warranty.

2- Consult factory for other type batteries than the standard one.

Emerg-Power Systems 3FTC THREE PHASE SERIES

Uninterruptible emergency lighting inverter system 4.8KVA –50KVA



For all fluorescent/incandescent or HID light loads

Features:

- 98% efficient @ full load
- PWM/IGBT technology
- Self-testing/Self-diagnostic
- User programmable with password protection
- Standard input circuit breaker
- Standard internal bypass switch
- RS232 communication port
- Micro-processor controlled
- Automatic event and alarm log
- 90 min. standard run time
- Generator compatibility
- Available in Y or Δ input configuration
- Custom voltages available
- Automatic event, test and alarm log
- LCD display
- Reduced footprint
- Maintenance free standard batteries
- Forced air cooling during emergency only

UL listed to UL924. Meets NFPA101, NFPA70, NFPA 110, OSHA, UBC, SBCCI. N.Y City approved.

ELECTRICAL/MECHANICAL CHARACTERISTICS⁽⁴⁾ (data provided for standard lead calcium batteries)⁽¹⁾⁽⁴⁾

Power Rating ⁽²⁾ kVA/kW	Effic. at full load %	Max. input current (A)		Heat loss in normal mode (BTU/hr)	Batt. VDC	Batt. A	No. of batt.	UPS cabinet dimensions			Battery cabinet dimensions ⁽³⁾			No. of batt. cab.	Batt. cab. weight lbs (empty)	UPS cab. weight lbs	Batt. weight lbs	Total system weight lbs
		120/208V	277/480V					W"	H"	D"	W"	H"	D"					
4.8	98	17	7	326	144	39	12	30	47	25	30	47	25	1	210	535	888	1633
6	98	21	9	408	180	39	15	30	47	25	30	47	25	1	210	535	1110	1855
8	98	28	12	544	240	39	20	30	47	25	30	47	25	1	232	535	1480	2247
10	98	35	15	680	144	81	24	30	47	25	30	47	25	2	420	639	1776	2835
12.5	98	43	19	850	180	81	30	30	47	25	30	47	25	2	420	639	2220	3279
16.7	98	58	25	1136	240	81	40	30	47	25	30	47	25	2	464	639	2960	4063
24	98	84	36	1632	240	117	60	48	72	31	48	72	31	1	700	1250	4440	6390
33	98	115	50	2244	240	160	40	48	72	31	48	72	31	2	1300	1250	6080	8630
40	98	139	60	2720	240	194	100	48	72	31	48	72	31	2	1300	1450	7400	10150
50	98	174	75	3400	240	243	60	48	72	31	48	72	31	2	1300	1450	9120	11980

1- consult factory for 20 year type batteries or for wet nickel cadmium batteries

2- KVA=KW

3- battery cabinets up to 16.7KVA are stackable. To be installed on the right side of the electronics cabinet

4- special voltages or batteries may change the size, weight or number of cabinets

ORDERING INFORMATION

Example: 277/480SG24000-3FTC-277/480-90-ICB-RS232-MBYP-OCB1220-DCS-20Y

Input voltage ⁽³⁾	Battery type	VA/W rating	System type	Output voltage ⁽³⁾	Run time ⁽²⁾	Input breaker	RS232 port	Internal Bypass Switch	Output breakers ⁽⁴⁾	Options ⁽¹⁾
120/208 277/480	SG - sealed lead calcium NC - wet nickel cadmium	4800 6000 8000 10000 12500 16700 24000 33000 40000 50000	3FTC	120/208 277/480	90	ICB	RS232	MBYP	OCBxxxx - no trip alarm OCAxxxx - with trip alarm	20Y - 20 yr sealed batteries 12HR - 12 hr fast recharge NOFF - normally off output 1PH ⁽⁶⁾ EMBP - external bypass switch ⁽⁵⁾ RMP - remote metering panel RSAP - remote summary alarm panel DCS - dry summary alarm contacts INVON - inverter on dry contacts NOFF3 - normally OFF output 3PH ⁽⁶⁾ MOD - external modem FAX - fax modem BPR - bypass relays DIAL - autodialer SEIS - seismic mounting ZONEM - zone monitoring BATM - battery cycle warranty monitor

1- see page 12 for options description

2- other run times available

3- special voltages may change the size, weight or number of cabinets. 3 wire, Δ input configuration available.

4- max. 12 unsupervised single pole positions or 8 with trip alarm, up to 16.7kVA systems. 24 unsupervised or 16 with trip alarm for systems 24kVA to 50kVA. For more output breakers please consult factory. See page 12 for output breakers option details.

5- external bypass switch is not compatible with integrated output circuit breakers. Input/output voltage has to be the same

6- normally off loads cannot exceed 20% of total KVA rating with any combination of H.I.D. loads.

SYSTEM SPECIFICATIONS

GENERAL

Design	Stand-by no break. PWM inverter type utilizing IGBT technology with 2ms transfer time.
Control	Microprocessor controlled , 2 x 20-character display with touch pad controls & functions 5 LED indicators & alarm with ring-back feature
Metering	Input & Output Voltage, Battery Voltage, Battery & Output Current, Output VA, Temperature, Inverter Wattage
Communications	RS-232 port (DB9)

ELECTRICAL INPUT

Voltage	120/208 or 277/480 3 phase 4-wire +10% - 15%. Contact factory for all other voltages.
Input Power Walk-In	Limiting inrush current to less than 125%, 10 times for 1 line cycle
Input Frequency	60Hz, +/-3%, 50Hz available upon request
Protection	Input Circuit Breaker
Harmonic Distortion	<10%
Power Factor	0.5 lag/lead

ELECTRICAL OUTPUT

Voltage	120/208 or 277/480VAC 3-phase 4-wire
Static Voltage	Load current change +/-4%, battery discharge +/-4%
Dynamic Voltage	+/-3% for +/-25% load step change, +/-6% load step change, recovery within 3 cycles
Harmonic Distortion	<3% THD for linear load
Output Frequency	60Hz +/- 0.05Hz during emergency mode
Load Power Factor	0.5 lag to 0.5 lead
Inverter Overload	115% for 5 minutes
Protection	Optional Distribution Circuit Breaker
Crest Factor	2.8

ENVIRONMENTAL CONDITIONS

Storage/Transport (C)	-4°F to 158°F (-20°C to 70°C) without batteries -0°F to 104°F (-18°C to 40°C) with batteries ⁽¹⁾
Operating temperature	System operates safely from 32°F to 104°F (0°C to 40°C) but optimum operation is between 68° F and 86°F (20°C to 30°C). Battery performance can be affected by temperature.
Altitude	<10,000 feet (above sea level) without de-rating
Relative Humidity	0 to 95% non-condensing
Audible noise	45 dBA @ 1m from surface in emergency mode

1- max. 3 months at 104° F (40° C)

SINGLE LINE DIAGRAM

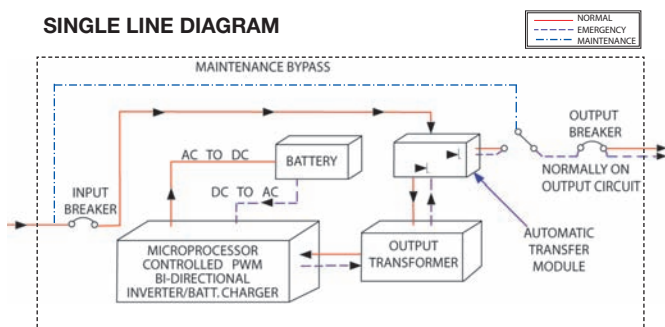

*output breakers are optional

CABINETS

Modular design, freestanding NEMA type 1 steel cabinets powder coated for corrosion and scratch resistance. Front access design through hinged lockable doors requires only 39" front clearance and 12" top clearance. Cabinets are stackable up to 16.7kVA, if required to further reduce the footprint. Top and left side conduit entry with knockouts up to 16.7kVA . Left side only for 24kVA and up.

INVERTER

Using IGBT/PWM technology the inverter converts the DC voltage supplied by the batteries to AC voltage of a precise stabilized amplitude and frequency, suitable for most sophisticated electrical equipment. True sinusoidal output waveform with very low distortion (less than 3% for linear loads). Overload capability of up to 150% for 12 line cycles.

CHARGER

Fully automatic, temperature compensated, microprocessor controlled charger recharges fully discharged batteries in maximum 24 hours at nominal AC input voltage. AC input current limiting and over-voltage protection included.

BATTERY

System is provided standard with 10 year, maintenance free, sealed valve regulated, front terminals lead calcium batteries. 20 years life sealed lead calcium or wet nickel cadmium batteries also available. 90 min. standard discharge time at full load under normal operating temperature. Low Voltage Disconnect protection included. No special ventilation or filters required.

SUPERVISION

Automatic self tests consist of a 5-minute monthly and 90-minute annual function. The front-mounted control panel includes 5 LED indicators, a 2-line 20-character LCD display, a keypad to control and monitor the internal operation of the system. This allows the operator to easily "watch" system functions as they occur and check on virtually any aspect of the system's operation. Standard RS232 diagnostic interface.

ALARMS

High/Low Battery Charger Voltage, High/Low AC Input Voltage, Near Low Battery, Low Battery, Load Reduction Fault, Output Overload, High Ambient Temperature, Inverter Fault, Output Fault, Optional Output Circuit Breaker Trip

OPTIONAL FEATURES

Output Circuit Breakers, Output Trip Alarms, 20 Years Sealed Batteries, 12 Hours Fast Recharge, External Maintenance Bypass Switch, Remote Meter Panel, Remote Summary Alarm Panel, Summary Alarm Dry Form C Contact, Inverter on Dry Contacts, Normally OFF output, Fax/Modem, Bypass Relays, Auto Dialer, Seismic Mounting.

FACTORY START-UP

Includes one additional year of warranty. See warranty conditions

WARRANTY

(full limited warranty conditions available upon request)
Limited manufacturer warranty is one-year, parts and labor, for system electronics or two-year with factory start-up program. Battery warranty is one year full plus 9 years pro-rata for a total of 10 years, under normal operating conditions. System must be put in service within 6 months from ship date in order to validate warranty.

2-Consult factory for other type batteries than the standard one.

Emerg-Power Systems FTC3R & 3FTC3R OUTDOOR SERIES

Outdoor uninterruptible emergency lighting inverter system 3KVA –8KVA



For all fluorescent/incandescent or HID light loads

Features:

- 98% efficient @ full load
- PWM/IGBT technology
- Self-testing/Self-diagnostic
- Standard input circuit breaker
- Standard internal bypass switch
- RS232 communication port
- Standard seismic zone 4 brackets
- Standard summary dry contacts
- Automatic event and alarm log
- NEMA 3R cabinet for outdoors
- 90 min. standard run time
- Generator compatibility
- Custom voltages available
- Automatic event, test and alarm log
- LCD display
- One size cabinet
- Maintenance free standard batteries
- Temperature controlled cooling fans

UL listed to UL924. Meets NFPA101, NFPA70, NFPA 110, OSHA, UBC, SBCCI. N.Y City approved.

ELECTRICAL/MECHANICAL CHARACTERISTICS ^{(3) (4)}

Power Rating kVA/kW	Effic. at full load %	Heat loss BTU	Batt. VDC	Batt. A	Number of batt. (2)	UPS cabinet dimensions			UPS cab. weight lbs	Batt. weight lbs	Total system weight lbs
						W" (1)	H"	D"			
3 (1PH)	98	255	120	37	10	48	76	30	535	888	1633
4 (1PH)	98	340	144	40	12	48	76	30	535	1110	1855
5 (1PH)	98	408	180	40	15	48	76	30	535	1480	2247
6.5 (1PH)	98	544	240	39	20	48	76	30	639	1776	2835
8 (1PH)	98	680	144	82	24	48	76	30	639	2220	3279
4 (3PH)	98	326	144	39	12	48	76	30	639	2960	4063
5 (3PH)	98	408	180	39	15	48	76	30	1250	4440	6390
6.5 (3PH)	98	544	240	39	20	48	76	30	1250	6080	8630
8 (3PH)	98	680	144	81	24	48	76	30	1450	7400	10150

1- factory installed floor mount brackets; add 2.5" to each side (total 53")

2- standard batteries are 5 year life expectancy. Batteries are installed in the same cabinet with electronics.

3- UL rated for 90 min. run time for temperatures: 50°F to 104°F (10°C to 40°C) or -4°F to 104°F (-20°C to 40°C) with optional heater.

4- NEMA type3R, freestanding, two-door powder coat cold rolled steel cabinet standard. Stainless steel enclosure is optional.

ORDERING INFORMATION

Example: 277/480SG5000-FTC3R-277/480-90-ICB-RS232-MBYP-OCB1020-DCS-20Y

Input voltage ⁽³⁾	Battery type	VA/W rating	System type	Output voltage	Run time ⁽²⁾	Input breaker	RS232 port	Internal Bypass Switch	Output breakers ⁽⁴⁾	Options ⁽¹⁾
120, 1PH 208, 1PH 240, 1PH 277, 1PH 120/208, 3PH 277/480, 3PH	SG - sealed lead calcium	3000 ⁽⁵⁾ 4000 5000 6500 8000	FTC3R – single phase 3FTC3R- 3 phase	120 208 277 120/208 277/480	90	ICB	RS232	MBYP	OCBxxxx - no trip alarm OCAxxxx - with trip alarm	10Y - 10 yr sealed batteries 12HR - 12 hr fast recharge NOFF - normally off output ⁽⁶⁾ EMBP - external bypass switch ⁽⁵⁾ RMP - remote metering panel RSAP - remote summary alarm panel HTR - heater INVON - inverter on dry contacts MOD - external modem FAX - fax modem BPR - bypass relays SS - stainless steel enclosure

1- see page 12 for options description. Summary alarm dry contacts and seismic brackets are standard.

2- other run times available

3- 1PH are input voltages available for 1 phase systems. 3PH are input voltages available for 3phase systems.

4- max. 14 unsupervised single pole positions or 8 with trip alarm. See page 12 for output breakers option details.

5- not available in 3 phase version

6- normally off loads cannot exceed 20% of total KVA rating with any combination of H.I.D. loads.

SYSTEMS OPTIONS -DETAILS-

*See the ordering information pages for the applicable list of options for each system type

INTEGRATED OUTPUT CIRCUIT BREAKERS:

-OCB	12	20			
Trip Alarm OCB - No Breaker Trip Alarm OCA - With Breaker Trip Alarm	Number of Circuit Breakers Combination of 1 pole, 2 pole and 3 pole breakers available. *For max. number of circuit breakers available please consult factory	Breaker Rating (Amps) *Various ratings available	Number of poles Blank - 1 pole -2P - 2 poles -3P - 3poles	Breaker Voltage Blank- matches system output voltage -120VAC -208VAC -240VAC -277VAC -480VAC	Operation Mode Blank : Normally-On -NOFF : Normally-Off

Distribution circuit breakers are for output load protection. Protection for the normally on and/or for the normally off loads. All circuit breakers are rated for 10,000 AIC.

If ordered, an audible and visual alarm activates when an output distribution circuit breaker is open or has tripped.

(-20YR) 20 Year Sealed Lead Calcium Batteries

Maintenance free battery requires no addition of water over the life of the battery. The battery cells are housed in protective, modular steel trays. Life expectancy is designed for 20-years at 77°F (25°C).

(-12HR) 12 Hour Fast Recharge

Battery charger upgrade option which decreases the time required to return a fully discharged battery to the fully charged state. The normal 24 hour recharge cycle is reduced to a 12 hour period.

(-MBYP) Internal Maintenance Bypass Switch

Internally mounted device permits maintenance personnel to easily bypass the protected equipment directly to the AC utility power. The manual make before break switch isolates the system to perform routine maintenance or servicing without interruption of utility power to the connected load.

(-EMBP) External Maintenance Bypass Switch

The external maintenance bypass switch is mounted in a 20" H x 16" W x 9" D NEMA 1 separate enclosure, used to completely isolate the inverter system from the connected load and AC utility input. This option allows the system to be safely powered down for maintenance or service. The option may not be used on systems with more than one single pole output circuit breaker which must be sized for the total system output current.

(-RMP) Remote Meter Panel

The panel allows monitoring of parameters and control from remote locations up to 150 feet away from the inverter system. Also, the remote panel provides a complete touch pad interface allowing the user to monitor, control and program the inverter system.

(-RSAP) Remote Summary Alarm Panel

Wall mountable box provides visual and audible alarms with silent switch. The panel consists of LED indicators and built in audible alarm and may be located up to 1,000 feet away from the inverter system.

(-DCS) Summary Alarm Dry Contacts

Form C dry contacts for remote monitoring purposes. Rated at 5 amps max. (250VAC/30VDC), the contacts will change state when any of the following alarms: High/Low Battery Charger Voltage, High/Low AC Input Voltage, Near Low Battery Voltage, Low Battery Voltage, Load Reduction Fault, High Ambient Temperature, Inverter Fault, Output Fault, Output Overload or Optional circuit breaker trip alarms, occurs.

(-INVON) Inverter On Dry Contacts

Form C dry contacts that will change state when the system transfers to battery operation

(-VTD) Variable Time Delay (for normally off circuits)

After a return of AC utility power, delays retransfer of the inverter for up to 15 min. and continues to supply emergency power to the normally off circuits.

(-NOFF) Normally Off Output

This output circuit is dedicated for the emergency only equipment. Emergency only equipment operates during power outages and when the system is on battery back up. This option leaves the normally off load circuits off during normal utility power conditions. A 1-pole circuit breaker is provided. For 3 phase systems, 3 pole normally off circuits are available as well.

(-MOD) External Modem

External modem device is designed to boost the signal level of the RS-232 diagnostic interface to remote monitoring locations located more than 100 feet away from the system.

(-FAX) Internal Fax Modem

The internal fax modem enables the system to send a fax automatically to several pre-programmed numbers when one of the following conditions occurs: utility failure, output failure or any alarm. The Fax Modem option requires a user supplied dedicated phone line.

(-BPR) Bypass Relays

Internal bypass relays will allow overriding circuits that can be switched on/off, so in case of a power failure the emergency circuits will be supplied from the inverter system whatever the position of the switching device. Please consult factory for more details.

(-DIAL) Auto Dialer

The Auto Dialer modem option automatically dials up to four user-programmable phone numbers in the event of any system alarm condition. The option is designed to deliver a predetermined digital or audible message when activated. The Auto Dialer option requires a user supplied dedicated digital or analog phone line.

(-SEIS) Seismic Mounting Kit

The seismic mounting kit option is designed to prevent system movement during seismic events. Heavy duty brackets are provided to secure system cabinetry to floor surfaces. Meets Zone 4 requirements.

(-ZONEM) Zone Monitoring

Allows voltage monitoring of different circuits than the standard AC utility input. When the voltage of one of these circuits drops, the inverter system will go into battery back-up operation mode. Number and voltage of the monitored circuits to be specified.

(-RS232) Diagnostic Interface

A microprocessor-based data acquisition system designed to monitor all the system parameters remotely. Monitors alarm log, event log and automatic test log. User can command the system to perform a battery test and review all system parameters. Access is through a DB9 connector and transmits at 9600 baud.

(-BATM) Battery Cycle Warranty Monitor

Device providing battery monitoring at string level or cell level. Please consult factory for more details.

CONTROL PANEL & DISPLAY FUNCTIONS

Meter Functions

- AC Voltage Input
- AC Voltage Output
- AC Current output
- Battery Voltage
- Battery Current
- VA Output
- Inverter Watts
- Ambient Temperature
- System Days (cumulative)
- Inverter Minutes (cumulative)

Alarms

- High Battery Charger Voltage
- Low Battery Charger Voltage
- High AC Input Voltage
- Low AC Input Voltage
- Near Low Battery Voltage
- Low Battery Voltage
- Load Reduction Fault
- High Ambient Temperature
- Inverter Fault
- Output Fault
- Output Overload

Program Functions

- Set Date
- Set Time
- Set Monthly Test Date and Time
- Set Annual Test Date and Time
- Set Load Fault Reduction Setting
- Set Low Battery Alarm
- Set Near Low Battery Alarm
- Set Low AC Voltage Alarm
- Set High AC Alarm
- Set Ambient Temperature Alarm

Control Functions

- Test and Event Logs (75 logs stored) Logs record the following data: Date, Time, Duration, Output Voltage, Output Current, Ambient Temperature and Alarms Present.
- Alarm Logs (50 logs stored) Logs record the following data: Date, Time and Alarm type
- Buzzer On/Off (toggle)
- 5 LED Indicators and Alarms With Ringback Feature



System Testing

Systems provide one manual and two automatic test functions. Manual tests of system may be performed at any time using the control panel test key. Automatic self-diagnostic tests consist of a 5-minute monthly and 90-minute annual function (the user can program the date and time of day the test is to take place). The microprocessor automatically records the last 75 test events in its own separate test result log.

CENTRAL SYSTEM REQUEST DATA

1) Input voltage

Single phase (2 wire + ground) 120VAC 208VAC 240VAC 277VAC
 Three phase (4 wire + ground, Y) 120/208VAC 277/480V
 Three phase (3 wire + ground, Δ) 208VAC 480VAC

2) Output voltage

Single phase (2 wire + ground) 120VAC 208VAC 277VAC
 Single phase (3 wire + ground) 120/240V 120/277
 Three phase (4 wire + ground, Y) 120/208VAC 277/480V

3) System capacity

KVA rating : _____ System series type _____

- a) Please consider power consumption and maximum current of the complete lamp fixture not just the lamp wattage (ie: ballasts consumption)
- b) Please consider loads power factor
- c) Even if the systems can run with 100% load, it is recommended as standard practice to use a system with a capacity at least 10% over maximum connected load

4) Type of loads

Incandescent Fluorescent H.I.D (metal halide, high pressure sodium, etc.)
 Others _____

5) Mode of operation

Normally ON (24/7) Normally OFF (emergency only) Switched loads ON/OFF

- a) Please consider internal bypass relays or external override relays for switched On/Off loads. Each switched output circuit will require a bypass relay. Maximum 20 A per circuit.

6) Integrated output circuit breakers

of CB _____ Amps _____ Voltage _____ # of poles ____ NON NOFF Trip alarm

#of CB _____ Amps _____ Voltage _____ # of poles ____ NON NOFF Trip alarm

7) Type of batteries (check availability for each type system)

10 yr sealed lead calcium 20 yr sealed lead calcium wet nickel cadmium

8) Options (refer to available options for each type system)

- 12HR- 12 hr fast recharge
- MBYP- internal bypass switch
- EMBP- external bypass switch
- RMP- remote metering panel
- RSAP- remote summary alarm panel
- DCS- dry summary alarm contacts
- INVON- inverter on dry contacts
- RS232- diagnostic interface
- WB- wall mount bracket
- NOFF – normally OFF output
- MOD- external modem
- FAX- fax modem
- BPR- bypass relays How many _____
- DIAL- autodialer
- SEIS- seismic mounting
- ZONEM- zone monitoring
- VTD- variable time delay
- BATM – battery cycle warranty monitor

www.emergi-lite.com

Thomas&Betts

All information and specifications contained in this catalogue are subject to change due to engineer design, errors and omissions. Illustrations and diagrams within this catalogue may vary from actual products.

© 2008 Thomas & Betts Limited. All rights reserved. Printed in Canada 04/08/5000. Order No.: EL-InverterSystemsCAT-US