

## Mini-Revelation™ Series

The full retrofit unseen solution – 12V-40W capacities



### Housing

- Galvanized steel back-box
- Easy access to internal components
- Head assembly door and trim plate powder coated in a white finish
- Finish can be customized on site with paint or wallpaper
- Choice of various 12 volt MR16 LED lamp wattages
- Complete 360° head assembly door rotation
- Slip gear mechanism protects unit and objects against forcible stops

### Mounting

- Recessed wall with cavity mount (retrofit into finished wall)
- Designed to install into an 8-1/4" by 5-3/4" inch opening
- Key-hole slot for ease of installation

### Electronics

- Pulse plus charger
- Low voltage disconnect
- Automatic brownout protection
- Battery lock-out
- Fused output circuit
- Standard Advanced Diagnostics
- 120/277 60Hz

### Choice of sealed maintenance-free battery

- 12V lead-calcium battery
- 12V nickel-cadmium battery

### Approvals

- CSA-US (to UL 924 standards)
- NYC approved
- BC – California Energy Commission Title 20

### Warranty

- Unit has a five-year limited warranty
- Detailed warranty terms located on page 202 or online at:  
[www.emergi-lite.com/usa/files/EL\\_Warranty.pdf](http://www.emergi-lite.com/usa/files/EL_Warranty.pdf)

### Photometric performance

Lamp	Spacing center-to-center (feet)	
	7' mounting height	15' mounting height
LG	55'	43'
LI	71'	56'
LJ	100'	85'

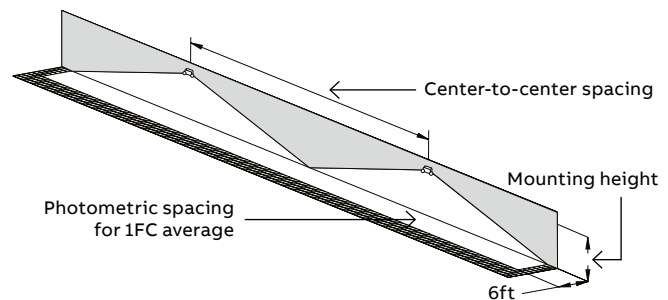

**Dimensions**

Dimensions are approximate and subject to change.

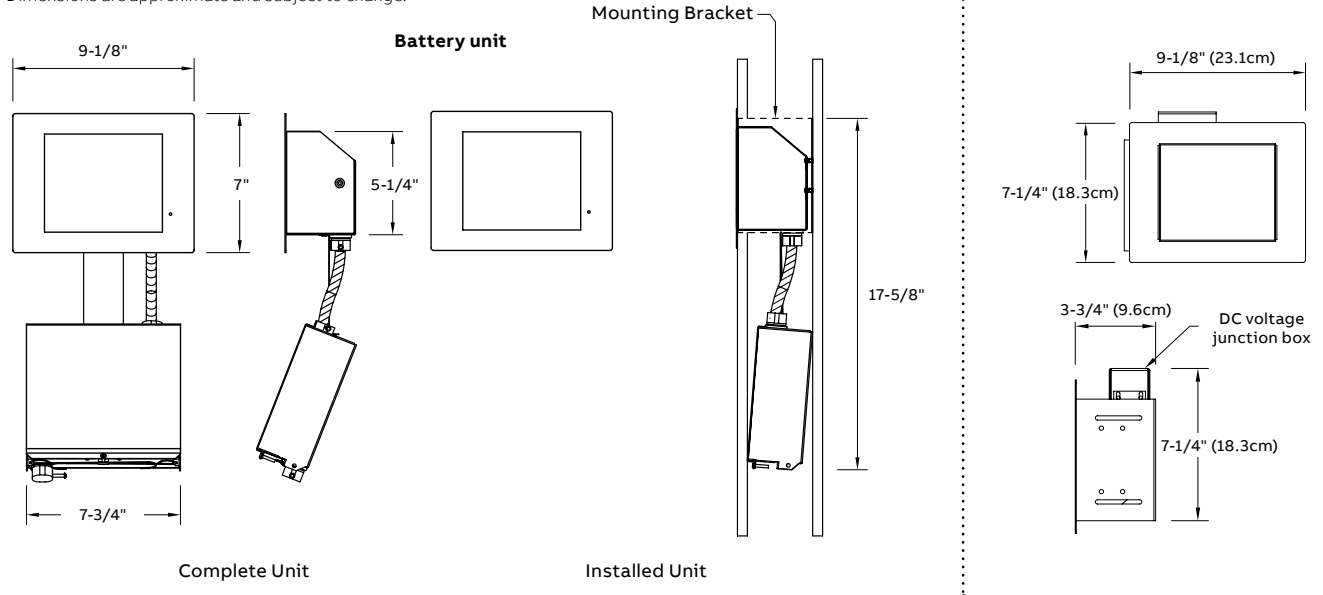

**Power consumption**

Non-CEC models	AC input	Input current	Maximum		Stand-by (Ni-Cd, NiMH) <sup>1</sup>	
			Input power	Input current	Input power	Input power
MRT40	120VAC	0.25A	30W	0.1A	11W	
	277VAC	0.12A	30W	0.05A	11W	
MRTG	120VAC	0.95A	110W <sup>2</sup>	-	-	
	277VAC	0.45A	110W <sup>2</sup>	-	-	

CEC model	AC input	Input current	Maximum		Stand-by	
			Input power	Input power	Input power	Input power
MRM40	120VAC	0.25A	30W		0.79W	
	277VAC	0.12A	30W		0.79W	

<sup>1</sup>Stand-by power consumption is 50% lower for lead-calcium batteries

<sup>2</sup>Maximum power when equipped with 2 x 50W lamps (generator unit)

**Unit rating**

Model	Watts to 87-1/2% of rated battery voltage <sup>1</sup>			
	1-1/2 hrs	2 hrs	4 hrs	8 hrs
MRT-40	40	30	24	-

<sup>1</sup>National Electrical Code specification

**Accessories** (order as a separate item)

Description	Suffix
Remote test switch (metal face plate)	RTS
Remote test switch (plastic face plate)	RTS-1

**How to order**

Series	Battery type	Unit capacity	AC input	Lamp type/wattage	Options	Approval
<b>Battery</b>	M= Lead-calcium	40= 12V-40W	Blank=	-2 (LG)= MR16 LED, 12V-4W	-AD= Advanced Diagnostics (audible) <sup>1</sup>	-CEC= CEC
<b>unit= MRT</b>	N= Nickel-Cd		120/277VAC	-2 (LI)= MR16 LED, 12V-5W	-ADNA= Advanced Diagnostics (non-audible) <sup>1</sup>	Title 20 for California <sup>3</sup>
				-2 (LJ)= MR16 LED, 12V-6W	-DL= Damp location (only MRTN40) <sup>2</sup>	
<b>Generator</b>	G= Remote AC generator	Blank= Max. 100W	1= 120VAC 2= 277VAC	-2 (LG)= 12V-4W, MR16 LED -2 (LI)= 12V-5W, MR16 LED -2 (LJ)= 12V-6W, MR16 LED	-DL= Damp location	

**Example: MRTM40-2(LJ)-ADNA**

<sup>1</sup>AD & ADNA include a time delay feature that can be enabled/disabled in the field or set by the factory

<sup>2</sup>Available with nickel-cadmium only

<sup>3</sup>Available with lead-calcium models only